

Mitchell Equipment

WE GOT YOUR BACK



**Mitchell
Equipment**

Jump Start Guide

2018 EDITION

WWW.MITCHELLEQUIP.COM

CASE IH
AGRICULTURE



MITCHELL EQUIPMENT RTK NETWORK MAP

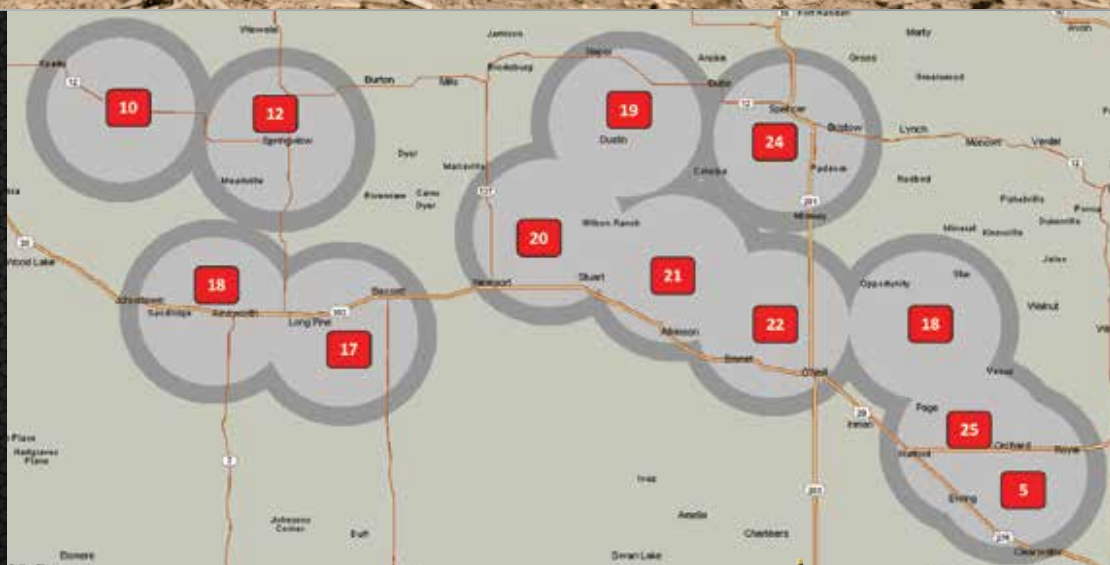

MITCHELL EQUIPMENT RTK

- ✓ Sub Inch Repeatable Accuracy
- ✓ Annual Subscription - \$750.00
- ✓ (price caps at \$3750 for 5 units)



SATELLITE BASED CORRECTION

- ✓ Centerpoint RTX / 1 Yr / \$1650*
- ✓ Omni HP / 1 Yr / \$1500*
- ✓ Omni HP / 3 Mos / \$850*
- ✓ Omni XP / 1 Yr / \$800*
- ✓ Omni XP / 3 Mos / 480*

*Price per unit activated



Mitchell Equipment

WE GOT YOUR BACK

CASE IH
AGRICULTURE

Precision
Planting



SECTION 1 - PLANTER PERFORMANCE

Contents

Planter & Tractor Check List.....	2
Daily Operation Wizard.....	3
Product Setup Wizard.....	6
Full Planter Setup Wizard.....	9
Calibrations.....	16
Planting Tips.....	19
Recommended Layout Screens.....	20

Planter & Tractor Check List

Planter settings and checks:

Meter: Cleaned out, correct discs installed, singulator set (corn 3, soybeans 8), baffles set to 2.

Fertilizer: Oil level, suction screen clean, proper orifices for rate to be applied.

Seed: Bulk tanks clean, lid seals good (no air leakage while bulk fan running) manifolds clean and dry.

Row unit: Zero out row units, down pressure (all springs set the same/air pressure holds), seed depth set.

Hydraulics: Case-drain hose hooked up (CRITICAL), PTO reservoir full, cooler fan should kick on and off as the PTO oil gets hot.

Drives: Make sure all of the drive chains are tight and no rusty kinks. A slightly loose chain will jump when under load and will cause seed gaps in field which won't be noticeable on the seed graph.

Tires: Check for correct tire pressure which will affect toolbar height.

Tractor settings:

Hydraulics: Remote timers set to constant for constant flow, flow control set to slightly more than needed.

Engine: Engine speed steady (1500 and above for hyd flow), keep speed changes steady (hyd drives react better).

Overlap & Boundary Control Tips

Checking Auto Section Control

1. Plant End Row
2. Plant across the end row at a 90 degree angle (Trying to get all rows to start and stop at same time)
Keep the planter in the ground well past stopping point and have planter in the ground well before the starting point. This ensures drives start and stop correctly.
3. Dig for Seed in all the rows to determine if drives are shutting off & turning on properly
See Section on overlap for adjusting the start and stop distances

Dig, Dig, Dig: You must dig behind each planter row periodically to determine that seed and fertilizer are getting to the correct depth and that the seed trench is getting closed up properly. Just because the seed graph says it is planting doesn't mean that the seed is where it needs to be.

Daily Operation Wizard

Recommend to use this procedure Every Day & Everytime you switch Fields

1) From the Main Page Select the Wizards Button

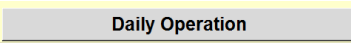
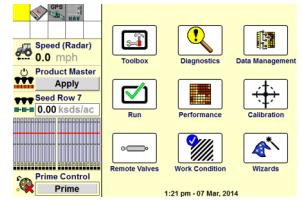

2) Select the Daily Operation Button

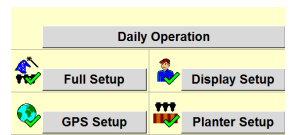

3) The first page of the Wizard will appear, if you hit the down arrow in lower LH corner you can access “Planter Frame Operation”, “Bar Raise” and “Marker Functions”. If your planter has markers you can turn them on or off here. Once Finished Select Next

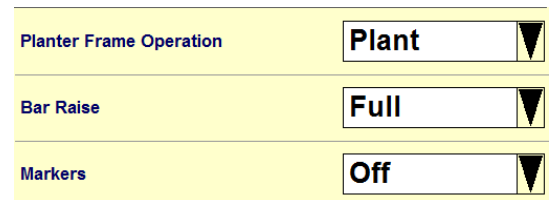
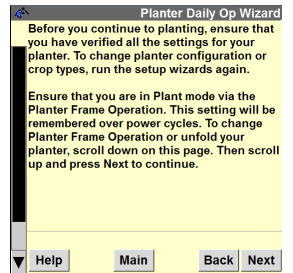

4) Select the Operator & Press Next

The display can save multiple operators

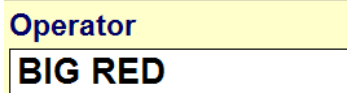

5) Select the Crop Type & Press Next

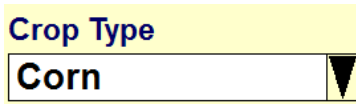

6) Select the correct Grower, Farm, Field and press next

Grower	<input type="text" value="4-CASE IH"/>
Farm	<input type="text" value="AXIAL FLOW"/>
Field	<input type="text" value="BIG RED 3"/>

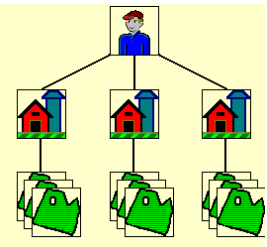

7) No action required, press next

If there is ever an instance where you have to Re-plant a field in the same growing season. The overlap control will think the field has already been planted. To plant a second time you will need to select a new operation instance.

Operation	<input type="text" value="Plant"/>
Operation Instance	<input type="text" value="Plant 1"/>
Task	<input type="text" value="14/03/04-19:43:05"/>

8) Select the appropriate work condition

Between crop types or seed plate changes.

If your work condition was set for single variety tracking and you want to do split variety tracking you will have to go through the full planter setup to change this.

Assign the seed products to the correct layer or layers.

Assign the liquid product to the correct layer, once finished press Next.

Work Condition	<input type="text" value="L/R Plant w/ Liq"/>
Layer 1	Product 1
Seed Left	<input type="text" value="1234"/>
Layer 2	Product 2
Seed Right	<input type="text" value="1234"/>
Layer 3	Product 3
Liquid	<input type="text" value="10-34-0"/>

9) If using planting prescriptions

Select the appropriate RX file for each layer & press Next.

Layer 1	Prescription 1
Seed Left	<input type="text" value="None"/>
Layer 2	Prescription 2
Seed Right	<input type="text" value="None"/>
Layer 3	Prescription 3
Liquid	<input type="text" value="None"/>

10) You can press & hold the planter systems start button. Need to have hydraulics & PTO engaged for startup. This will start & prime the planter. When completed press next.

Once completed the Start Button will change to a green check. If a system fails in the procedure you will get a red x. You can also select each individual control box and start the systems manually if desired. If done manually upon returning to run screens you will need to prime system to fill the seed plates.

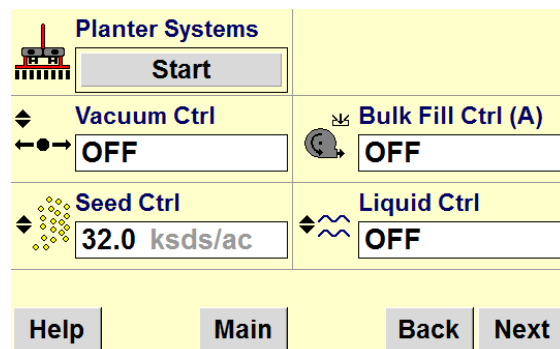

11) Select the run button to return you straight to the planter run screens for in field operations.

You have completed the setup wizards and daily operation. Press the Run button to go to the run screens.



Product Setup

Product Setup Procedure Using the Wizard

1) From the main page select the Wizards button

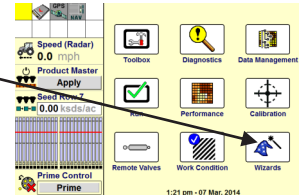

2) From Wizards Menu select Product Setup

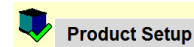

3) Adding new products
Select Product Name Box

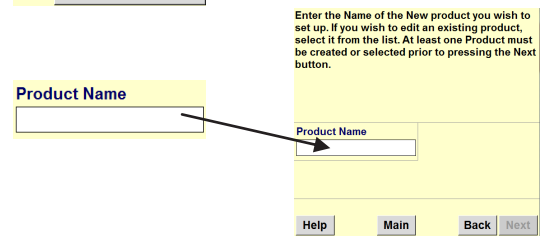

4) Select New from Product name box



5) Type in product name
If tracking varieties this is where you enter the variety numbers
For liquid products you could track the blends of fertilizer.

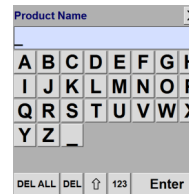

6) Select the form box
Use form type of seed or liquid
Do not use Bulk Seed

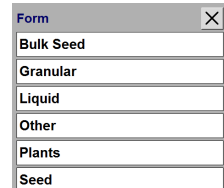
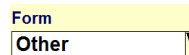

7) For Seed, set your crop type, select the crop type drop down box & press next.

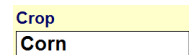

8) For liquid, set the usage, select the usage type drop down box & press next.

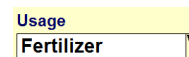

9) For seed & fertilizer you must set the default app rate, delta app rate, min app rate and max app rate.

Default App Rate

This is the rate that will default every time the monitor is powered on. If you increase or decrease from this number in the field, shut down the monitor and restart it will revert back to the default rate.

Delta App Rate

Amount the rate will change when selecting the left or right arrows in the rate control run screen window. If you manually increased your rate with a delta of 1.0 the rate would change from 32 to 33k seeds per acre.

Min App Rate

Lowest value planter will allow product to be applied. If using rx planting files, even if the rx tells the planter to apply a rate below this number the min app rate value set will override it. This needs to be set at or below your lowest rx rate.

Max App Rate

Highest value planter will allow product to be applied. If using rx planting files, even if the rx tells the planter to apply a rate above this number the max app rate value set will override it. This needs to be set at or above your highest rx rate.

Product Name		
1234		
Default App Rate	Delta App Rate	
32.0 ksd/s/ac Units	0.5 ksd/s/ac	
Min App Rate	Max App Rate	
20.0 ksd/s/ac	40.0 ksd/s/ac	

Product Name		
Fertilizer		
Default App Rate	Delta App Rate	
18.000 gal/ac Units	0.500 gal/ac	
Min App Rate	Max App Rate	
10.000 gal/ac	22.000 gal/ac	

10) Quick copy of products

If you have a product setup and all the app rates will stay the same for a new variety or blend you can copy it and only have to type in a new name.

11) From product setup wizard, first select from the product name drop down which product you want to copy. Once the product you want to copy is displayed in the product name window you can press that box again and select the copy for new product box.

Product Name
1234

Copy for New Product

12) Type in the new product name to be used & press next.

Product Copy X
1235_

13) Verify & change any default app rates for this new product and press next.

Product Name 1235		
Default App Rate 32.0 kds/ac	Units Units	Delta App Rate 0.5 kds/ac
Min App Rate 20.0 kds/ac		Max App Rate 40.0 kds/ac

14) To repeat these steps again select additional product - yes and continue to repeat steps until all products are entered.

Additional Product
Yes ▼

To Finish leave additional product - no & press next

Additional Product
No ▼

Full Planter Setup Wizard

The following is a step by step illustration through the full Planter Setup Wizard

This should only need performed once at the beginning of the season.

The rest of the Changes during season can be performed through the other wizards

1) From the main page select the Wizards Button

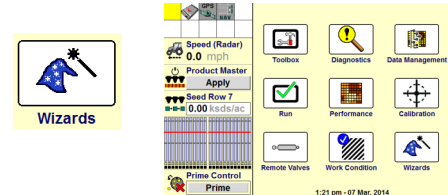

2) Select full setup & press next.

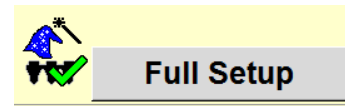

3) Select total rows & press next.

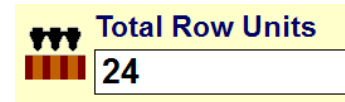

4) Select if you are using gps for mapping, guidance or overlap control and press next

Do you intend to use GPS in your operation, such as for mapping, overlap control, or autoguidance?

Yes No

5) Select if you are using section control or Accu-row clutches and press next

Do you intend to use section control or AFS AccuRow row clutch control?

Yes No

6) Select if you are using prescriptions and press next

Do you intend to use prescriptions for product rate control?

Yes No

7) Select if you are using containers and press next

Only used if you setup a container and use it to track amount of product remaining in hoppers or tank.

Do you intend to use the container function to track product remaining in your seed hoppers or liquid tanks?

Yes No

8) Select if you are tracking split varieties and press next

2 Varieties can be tracked for each half of the planter

Do you intend to do split-planter mapping?

Yes No

9) Select if you are using the factory liquid system

Stacker planters have to select no

Do you intend to use the factory supplied liquid fertilizer system?

Yes No

10) Select operator & display units

Monitor can store multiple users

Operator
BIG RED

Units
USA

11) Select crop type

Crop Type
Corn

12) Select grower, farm, field

Grower
4-CASE IH

Farm
AXIAL FLOW

Field
BIG RED 3

13) GPS setup should already be complete

DO NOT CHANGE IF USING GUIDANCE

There will be several screens to go through for gps setup. Continue pressing next.

GPS Location
Magnum Roof

Connection Type
CAN-A

Tractor Type
MFWD

14) Verify number of rows in each section

It may be necessary to physically count the rows that are driven by each seed drive motor to determine the number of rows in each section. Not all models are the same.

Implement	1255 FFT VR	
Section 1 Rows	12 rows	Section 2 Rows
	12 rows	12 rows

- 15) Verify row width and press next
Split row (15") planters will need 15" for row spacing even if only planting with the 30" rows

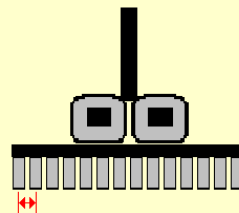
Implement	1255 FFT VR	
Row Width	30.0 in	

- 16) Set the Bar Distance and press next. This is a very critical part of overlap & section control.
Measure from the seed drop to the rear axle of the tractor.

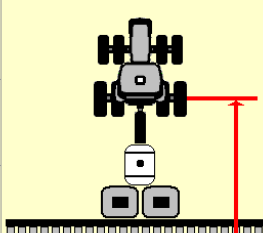
Implement	1255 FFT VR	
Bar Distance	320.0 in	

- 17) Select if you are using row clutch control and press next.
Clutch Type Electric = Cable Drive
Clutch Type Pneumatic = Air Clutches
Air Clutch Rows / Clutch Group = 2
Electric Clutch Rows / Clutch Group can be set to shut off rows individually (1 row per clutch group). If not running RTK it is recommended to leave the outer clutch groupings in this instance set at 2 to eliminate inadvertent shutoff due to satellite drift.

Implement	1255 FFT VR	
Row Clutch Control	Yes	Row Clutch Type
		Electric
Rows / Clutch Group	2 rows	

- 18) Select if using bulk fill, markers & granular in secticide boxes and press next

Implement	1255 FFT VR	Bulk Fill	Yes
Markers	No	Gran Chem Level	Yes
Liquid Product	Yes		

19) Select if you have bulk fill lights & in cab pneumatic down pressure control and press next.

Implement	1255 FFT VR
Bulk Fill Lights	No ▼
Down Force Ctrl	Yes ▼

20) Set your work condition and press next.

The work condition saves all of your calibrations & configurations for a specific crop. Example: If you plant corn with 2 different seed plates for dryland & irrigated you would want 2 different work conditions.

Work Condition	CORN SPLIT
-----------------------	------------

21) Set the seed cal value and press next.

Number of holes in the seed disk

Work Condition	CORN SPLIT
Seed Cal Value	48 cells/disk

22) Set the liquid cal value and press next.

Enter the number on the flow meter tag to start with. A calibration will be necessary to ensure accuracy.

Work Condition	CORN SPLIT
Liquid Cal Value (L)	433
Liquid Product Delay	2.00 Sec

23) Set the default bulk fill rate and press next.

Work Condition	CORN SPLIT
Bulk Fill Default Rate	3000 rpm Units

24) Set the default vacuum rate and press next.

Work Condition	CORN SPLIT
Vacuum Default Rate	18.0 in h2o Units

25) Planter swath offset leave zero.

Only used to correct for planter drift when using autosteer. Leave at zero until guess rows have been measured. This can be adjusted to constant wide or narrow guess row spacing.

Work Condition
CORN SPLIT
Intentional Overlap
0 rows
Planter Swath Offset
0.0 in

26) Set default down force control

Work Condition
CORN SPLIT
Down Force Ctrl
100 lbs

27) The calibration screen will now appear

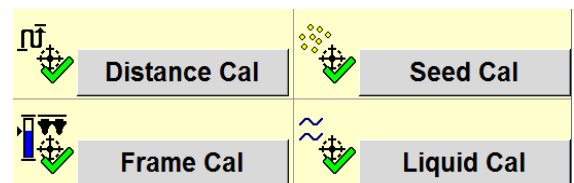

Distance Cal: Essential for accurate planting. This sets ground speed which in turn calculates acres. This can change with ground conditions. Best practice is to measure with half full of seed & fert with planter in ground

Seed Cal: Not normally needed more than once a year but is recommended if switching crops. Calibrates the hydraulic drives for the seed.

Frame Cal: Need to verify this so stop plant height isn't set to low and start height isn't set too high. If stop height is to low the planter can shutoff inadvertently through rough terrain.

Liquid Cal: Needs to be performed for every liquid blend run through the planter. If done correctly amount applied will be spot on with monitor.

28) Assign the products to the correct layers and press next.

The picture at right shows a split variety mapping setup. If you have not setup any products you can do that here. Refer to product setup section in this book for more info.

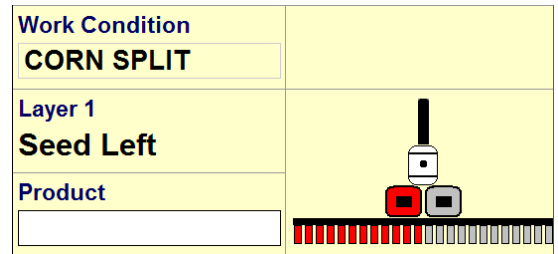

29) Verify or set default app rate and press next.

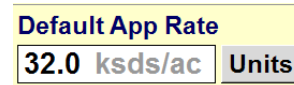

30) Verify or set min, max & delta rates and press next.

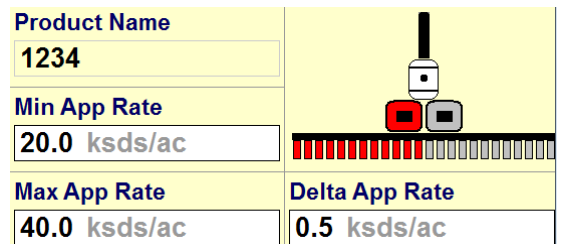

31) Assign liquid product if used and press next. Same sequence of screens as seed shown above.

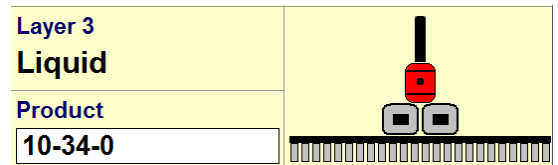

32) Verify overlap control settings and press next.

High percentage = prevent gaps, will keep sections on longer when overlapping already planted area

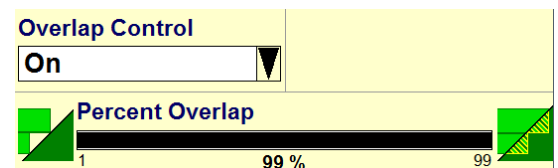

33) Verify boundary control settings and press next.

High percentage = prevents gaps, will keep sections on longer when crossing a frozen field boundary.

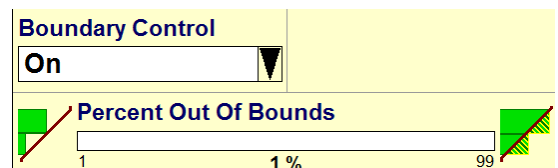

34) Set the product delay for seed



35) Overlap control

Start with distances set at zero. Increase distance for more overlap.

Start early distance = planting from the headlands into the field

Stop late distance = planting from the field into the headlands.

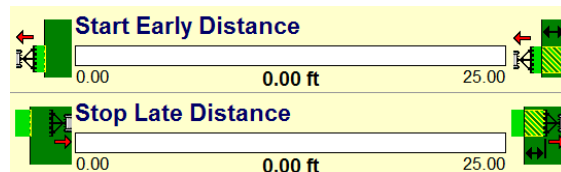

36) This will complete your full planter setup.

All wizards should now have a green check mark by them. This means that all conditions have been met for planter to run. However it does not mean that all settings were correct.

Strongly recommend going through the daily operation wizard every day or each field change to double check all settings are correct before planting.

	Full Setup		Display Setup
	GPS Setup		Planter Setup
	Layer Setup		Product Setup
	Overlap Setup		

Calibrations

Seed calibration is for Pulse Width Modulation (PWM) Valves.
Once calibration is ran it adjusts Cal Values without the operator even knowing.

Liquid Calibration is for the Flow Meter - Accurate Liquid Application Rates Depend on this Calibration.

Ground Speed Calibration is for the planter wheel speed sensors.
Correct ground speed is essential for accurate population.

Frame Calibration is for correct start and stop plant heights.

1. Seed Calibration - Select "Work Condition" "Seed"



A. Select Correct "Work Condition"

Work Condition
IRR CORN

B. Set Desired Calibration Speed

Speed
5.0 mph

C. Set Desired Calibration Distance

Distance
50.0 ft

D. Set Seed Disc Cal Value

Any time you change this number to change seed plates, it asks if you want to copy to all work conditions.
Select "NO"

Cal Value
48 cells/disk

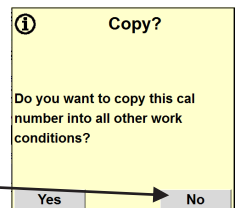

E. Select "Run"

Tractor hydraulics and PTO pump need engaged to run planter - Use "Prime" function before calibrating.

Start/Stop
Run

F. Operate Calibration Tether

Push and hold calibration button until drives quit turning.
After button is pressed, calibration takes a couple seconds before drives start turning.
If you let off button before the drives are done turning you must hit run button in cab to restart

You Can Use This Operation for Lubing Chains.
Set Calibration Distance to the max of 2000ft.

2. Liquid Calibration - Select “Work Condition” “Liquid”



A. Set Desired Calibration Speed

Speed
5.0 mph

B. Set Cal Value for Flow Meter

For initial calibration use tag on flow meter.
After running a calibration this value will change.

Cal Value (L)
433

C. Select “Run”

Same as Seed Cal: tractor hydraulics and PTO pump need engaged.



D. Operate Calibration Tether

Unlike Seed Cal, calibration can be started and stopped multiple times without pressing run button.

Display shows target rate per nozzle.

Target Per Nozzle
0.606 gpm

- (1) Hold tether until air is purged from system and flow and pressures even.
- (2) Catch a 1 Minute Sample - more accurate if you catch samples from multiple rows.
- (3) Measure Sample - if multiple rows caught average the rows together.
- (4) Divide number of ounces caught by 128 (128 Ounces in Gallon).

E. Enter Actual Flow

Number you calculated above compared to “measured” value.
Press Cal button after entering actual flow.
Repeat steps until you catch close to what is shown in “Measured”.

Actual Flow
0.000 gpm

Measured
----- gpm

You can use this process to flush system with water and antifreeze.
Use above steps and hold tether until flushed.
You will not need to enter calibration number.

3. Ground Speed Calibration - Select “Calibration” “Distance”



Distance Cal should be done each season.
Works best if in actual field conditions.

A. Measure 400ft in Field - Mark with Flags

B. Press “Start” at First Flag

Drive Course



C. Press “Stop” at Second Flag

Drive Course



D. Check “Left” and “Right” Measured Distance

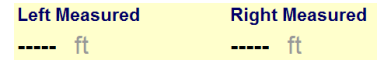

E. Select “Cal” for Both Left and Right

Will show Cal values for both.
Best to check twice for accuracy.



4. Frame Calibration - Select “Calibration” “Frame”

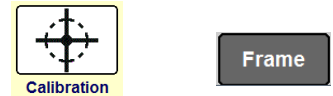

A. Unfold Height

Raise or lower toolbar to correct height and select “Cal”.

B. Start Plant Height

Raise or lower toolbar to correct height and select “Cal”.

C. Stop Plant Height

Raise or lower toolbar to correct height and select “Cal”.

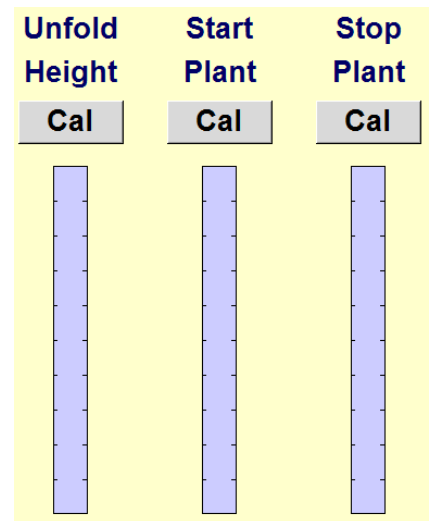

Planting Tips

Going to the field—To hook up planter to tractor, first plug the small 3/8 hydraulic hose in to the flat-faced connector and make sure it locks into place (this hose is the most important hose because it is the drain-off of excess pressure in the blower fans).

Then hook up other hoses. Hoses with Red caps go in No.1 remote valve for lifting/lowering/folding the planter. The others can go into any of the other remotes as long as you keep colors together. Hook up harnesses and PTO pump.

To fold or unfold, go BACK to main menu and select REMOTE VALVES. Select FRAME tab at bottom of screen and this brings you to a screen that shows PLANTER FRAME OPERATION and says OFF next to it. Select the OFF and gives you a list of OFF, PLANT, FOLD, UNFOLD. Select the one you want to perform and follow the steps (ex. To UNFOLD, select the Lower Wing Wheels tab “BACK” and, if your hoses are hooked up correctly, you should be able to move remote lever No. 1 back and the wing wheels will lower). Select one at a time and move the lever as the BACK/FORWARD commands and just follow the steps.

TO PLANT-- (any time after unfolding or starting the tractor up)

Go to REMOTE VALVES (MAIN MENU), select FRAME, and select PLANT. Then turn BAR RAISE to Full (LIMITED on pivot tongue planters). If using markers turn them to AUTO.

Then go BACK to MAIN and select RUN screens. Select RUN 2 and make sure that all of the boxes have something in them and you have the correct FIELD name, CROP type, and WORK CONDITION selected.

Go to RUN 4. Engage PTO and your remote valves that are hooked to run planters functions. SEED and LIQUID should already have the population that you want if RUN 2 was set up correctly. Select VACUUM and push ON and ENTER. VACUUM should run and will run wide open until it gets seeds in seed plates to create vacuum. Select BULK FILL and turn ON and enter. The HEADLAND AUTO OFF (when high-lighted) will shut off bulk fan when raising planter in order to save tractor oil for lifting.

PRIME—The PRIME button in LEFT AREA of the screen will allow you to fill seed plates and purge fertilizer system. Press and hold PRIME button for 2 seconds until it lights up. The planter drives should run for a couple of seconds. You may have to PRIME another time to get everything full. If seed came out of all rows and liquid is flowing, you should be ready to plant.

PLANT—If using markers, select arrow for which marker you want to go down first and lower the planter while moving (need to be moving to prevent mud getting in seed shoes).

SEED GRAPH—The seed graph shows 3 lines. The top line is high limit, bottom is low limit, and the middle is the default rate. If using row clutches, you will notice small squares beneath each row on seed graph. They are black when rows are turned on and turn gray when rows are outside of **boundary** or are **overlapped**. While planting, you can watch the rows shut off while crossing the lines (The little boxes show that rows should/shouldn't be planting but watch seed graph to verify).

HAPPY PLANTING!

Recommended Layout Screens for Planter

Follow Instructions in Guidance Portion of Booklet to Change Layout Screens.

Recommended layout screens for a planter running Accu-row clutches.

Run Screen	Run Screen	Number of Windows	Run Screen	Number of Windows	Run Screen	Number of Windows
Left Area	Run1	2 x 6	Run2	2 x 6	Run3	2 x 6
Ground Speed	Seed Ctrl	Seed Scan	Grower	Implement	Swath 1 Record 2x1	Swath 1 Record 2x1
Row Scan	Vacuum Ctrl	Vacuum Avg	Farm	Work Condition	Swath Number	Swath Select
Planter Systems	Bulk Fill Ctrl	Bulk Fill Rate	Field	Operation Instance	Swath Manage	Nudge
Prime Ctrl	Liquid Ctrl	Liquid	Task	Operation	GPS Heading	Re-mark
Seed Graph 1x2	Marker Ctrl	Obstacle Ctrl	Crop Type	Work Control	Cross Track Err	Trim
Seed Graph 1x2	Section 1 2	Overlap Control	Tag	Area, Total Field	Aggressiveness	Guidance Engage
Run Screen	Run Screen	Number of Windows	Run Screen	Number of Windows	Run Screen	Number of Windows
Run4	Run5	2 x 6	Run6	2 x 6		
Boundary Area	Boundary Control		Boundary Area	Area Remaining	Product 1 Amt App	Boundary Control
Area Remaining	Overlap Control		Boundary Record	Area, Total Field	Product 1 Amt Req	Overlap Control
Clutch Ctrl, Manual, 2x4	Clutch Ctrl, Manual, 2x4		Swath Map 1x4	Map 1x4	Product 1 Avg Rt	Compressor Pressure
Clutch Ctrl, Manual, 2x4	Clutch Ctrl, Manual, 2x4		Swath Map 1x4	Map 1x4	Product 2 Amt App	Down Pressure
Clutch Ctrl, Manual, 2x4	Clutch Ctrl, Manual, 2x4		Swath Map 1x4	Map 1x4	Product 2 Amt Req	Down Force Ctrl
Clutch Ctrl, Manual, 2x4	Clutch Ctrl, Manual, 2x4		Swath Map 1x4	Map 1x4	Product 2 Avg Rt	Down Force

Recommended layout screens for a planter running Accu-row clutches & Accu-stat seed monitoring

Run Screen	Run Screen	Number of Windows	Run Screen	Number of Windows	Run Screen	Number of Windows
Left Area	Run1	2 x 6	Run2	2 x 6	Run3	2 x 6
Ground Speed	Seed Ctrl	Seed Scan	Boundary Area	Boundary Control	AcStat CV Avg	AcStat CV Scan
Row Scan	Vacuum Ctrl	Vacuum Avg	Boundary Record	Overlap Control	AcStat Singulation Avg	AcStat Singul. Scan
Planter Systems	Bulk Fill Ctrl	Bulk Fill Rate	Clutch Ctrl, Manual, 2x4	Clutch Ctrl, Manual, 2x4	AcStat Skips Avg	AcStat Skips Scan
Prime Ctrl	Liquid Ctrl	Liquid	Clutch Ctrl, Manual, 2x4	Clutch Ctrl, Manual, 2x4	AcStat Multiples Avg	AcStat Multiples Scan
Seed Graph 1x2	Marker Ctrl	Obstacle Ctrl	Clutch Ctrl, Manual, 2x4	Clutch Ctrl, Manual, 2x4	AcStat Graph 2x2	AcStat Graph 2x2
Seed Graph 1x2	Section 1 2	Overlap Control	Clutch Ctrl, Manual, 2x4	Clutch Ctrl, Manual, 2x4	AcStat Graph 2x2	AcStat Graph 2x2
Run Screen	Run Screen	Number of Windows	Run Screen	Number of Windows	Run Screen	Number of Windows
Run4	Run5	2 x 6	Run6	2 x 6		
Product 1 Amt App	Product 2 Amt App		Farm	Field	Swath 1 Record 2x1	Swath 1 Record 2x1
Product 1 Amt Req	Product 2 Amt Req		Boundary Record	Work Condition	Swath Number	Swath Select
AcStat Singul. Grph 1x1	Compressor Pressure		Swath Map 1x4	Map 1x4	Swath Manage	Nudge
AcStat Summary 1x3	Down Pressure		Swath Map 1x4	Map 1x4	GPS Heading	Re-mark
AcStat Summary 1x3	Down Force Ctrl		Swath Map 1x4	Map 1x4	Cross Track Err	Trim
AcStat Summary 1x3	Down Force		Swath Map 1x4	Map 1x4	Aggressiveness	Guidance Engage

SECTION 2 - GUIDANCE PERFORMANCE

Contents

Basic Display Setup.....	24
Run Screen Layouts - Setup & Changing Grower, Farm, Field Setup.....	25
Implement Setup.....	28
Accuguide Guidance Setup.....	29
Accuguide Guidance Operation.....	30
Boundary Recording.....	33
Filtering Crop List.....	35
Recommended Layout Screens.....	36

Basic Display Setup

1. Display Setup - Select "Toolbox" "Disp"

A. Set desired info for Date and Time

B. Interface Level
 (1) Advanced
 (2) Basic

C. Back Light - Screen Brightness

2. Operator Setup - Select "Toolbox" "Oper"

A. Select or add new Operator

B. Select desired Display Mode and Units

C. Set desired Display Volume (Pro 700)

Changing Layout Screens for Pro 600 / Pro 700

Steps for Changing Layouts

1. Starting from “Run Screens” select “Back”



2. Select “Toolbox” - “Layout”



3. If you have not created a new layout, continue to Step 3.a.

If you have already created a new layout, continue to Step 4.

A. Select box showing default

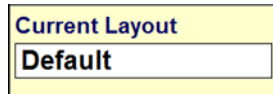

B. New box will appear - Select “New”

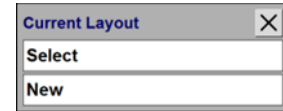

C. Type name for new layout

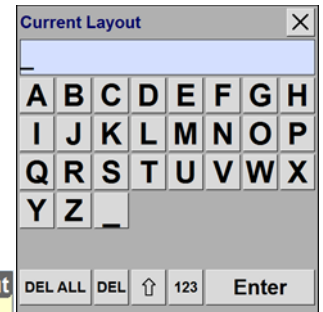

You can have more than 1 layout saved.
We recommend having different layouts saved for
the different operations.

4. Select “Run Screen” drop down
box

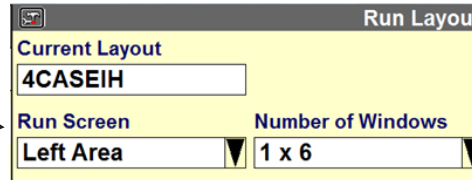

5. You can change the far left area as well as the 6 run
screens

6. Select which one you want to change

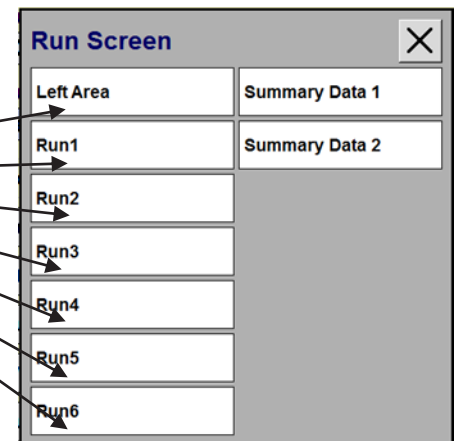

7. Select the item that you wish to change.
 A. You can change any of the white Boxes.

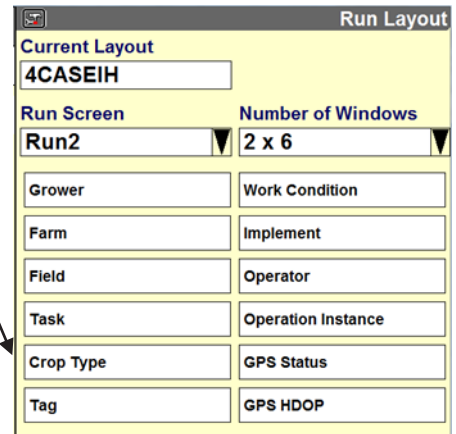

8. After selecting the box to change, a new window appears.
 A. Select new item you want displayed.
 B. The list is in alphabetical order.

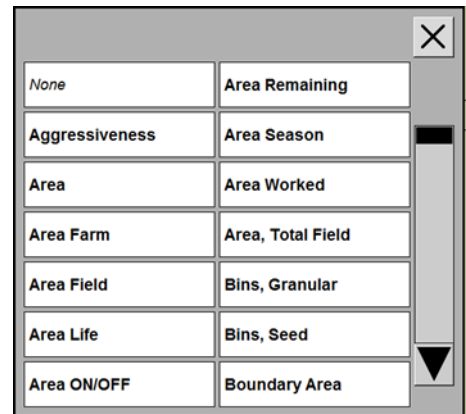

9. We advise displaying the following items on Run Screens 2 and 3.
 A. Use the below screen shots for reference on what to display on Run2 & Run3
 See back of guidance portion for guidance only run screen formats.
 See back of planter portion for setting up planter / guidance run screens.

Run Screen	Number of Windows
Run2	2 x 6
Grower	Implement
Farm	Work Condition
Field	Operation Instance
Task	Operation
Crop Type	Work Control
Tag	Swath Select

Run Screen	Number of Windows
Run3	2 x 6
Swath 1 Record 2x1	Swath 1 Record 2x1
Swath Manage	Swath Select
GPS Heading	Re-mark
GPS Status	Trim
Cross Track Err	Nudge
Aggressiveness	Guidance Engage

Grower - Farm - Field Setup

Steps for Setting up Grower, Farm, Field

We recommend for operations that are running more than one display that all data be entered into desktop software program and then exported for all displays to use.

Grower
Farm
Field

Recommend having 1 Grower
 Recommend having 1 Farm
 With having just 1 Grower and 1 Farm
 all of your fields will show up in one drop down list under the field selection.

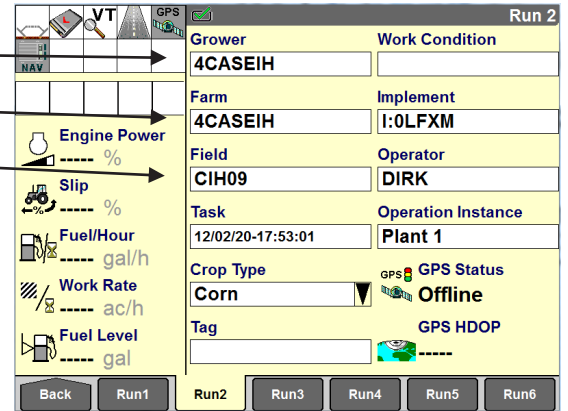
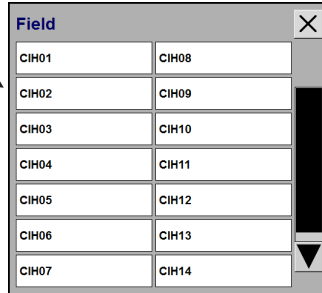

1. From "Run 2" screen you can select or add new Growers, Farms and Fields.

A. By selecting the white boxes for each it will bring up a new window.

B. If data has already been entered press the "Select" option

C. If you need to create new data press the "New" option

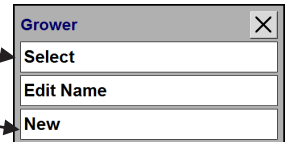

If you select "New" a popup keyboard will appear.
 Enter in the new Grower, Farm or Field.
 Repeat this step for all the info.

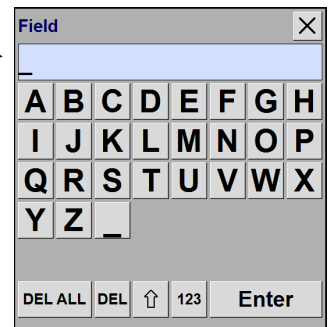

Again we recommend doing this in desktop software so the only thing you have to do is select the field and you are ready to go to work.

Implement Setup

Steps for correctly setting up implements.

1. Select "Toolbox" then "Impl"



2. Choose from previously saved impl or add new

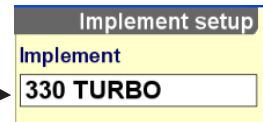

A. After selecting box above a new window appears.

B. Select existing saved implements.

C. Add new implements.

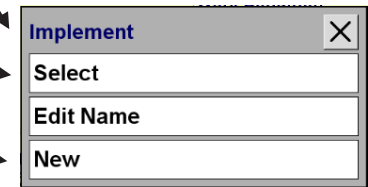

3. Adding new impl - after making new you can always change the settings below

A. Enter name of Implement - Will be saved for future use

B. Enter Work Condition

C. Implement Type

Two Selections

EHR1 Works w #1 Remote

When remote is pushed forward mapping Begins. You can bring remote back to neutral and mapping will continue. When remote is pulled back mapping will stop. This controls on screen map and performance monitor.

Hitch Works w/ 3Point Hitch

When hitch is lowered mapping begins. When hitch is raised mapping stops. Same as above, this will control on screen map and performance monitor.

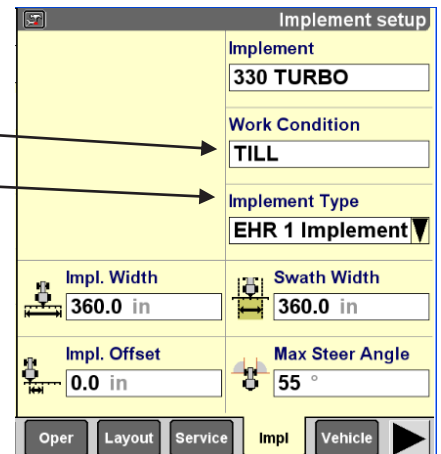

D. Swath Width

Working width of implement
Used for distance between field passes
I.E. 12R30 Strip till = 30ft = 360in
I.E. 34ft Disk w/ 32ft Cut Width = 32ft = 384"



E. Impl Width

Actual width of implement.
Generally same width as swath width.



Accuguide Guidance Setup

Steps for correct setup before operation.

1. Make sure implement setup correctly.
2. Make sure Grower / Farm / Field inputted correctly.
3. Correctly adjust guidance Settings

A. Select "Toolbox" then "Nav"



B. Select "Min Turning Radius"

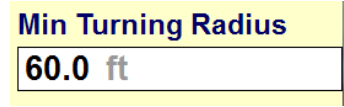

General rule of thumb same width as implement.
 I.E. 24R30 Planter = 60ft - Min Turning Radius = 60ft
 If left at default 164ft, during recording of curved swath
 If encountering tight turn the swath will generate at the
 minimum radius of 164ft - See Example at right.
 Tractor was driven at tighter radius than what was set in "Min Turn"
 Guidance line will be recorded as shown by circle.

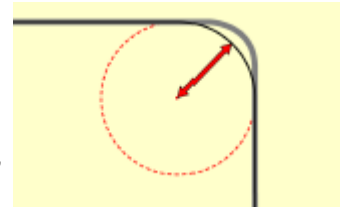

C. Nudge / Trim Increment

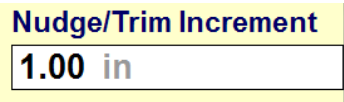

When using Trim or Nudge in field this will
 be the amount it will move every tap of the arrow.
 Generally we use 1".

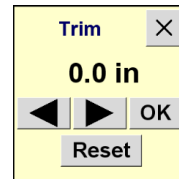

Accuguide Guidance Operation

Steps for correct guidance operation.

1. Guidance Operations - Select "Run 3"



2. Upon startup of display you must "Start" Accuguide System

A. Select "Start"

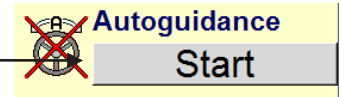

B. Select "Accept" on safety info page

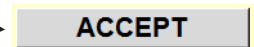

3. Swath Recording - Select Swath Type - We are only covering the top 3 that are used.

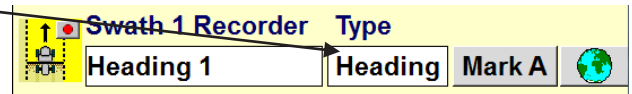

Straight - Set "A" and "B" points and line is drawn between them.

Heading - Set "A" point and enter heading degrees and straight line is drawn.

Curve - Set "A" point and swath will record exact path of travel until "B" point is set.

A. Straight Line Directions

(1) Select "Straight"

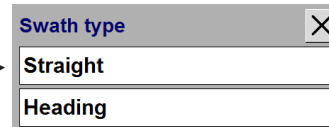

(2) Select blank "Swath Record" box.

(3) Select "New".



(4) If your vehicle is in correct place to begin, Select "Mark A".



(5) Drive to location in field where "B" point can be set and select "Mark B".



B. Heading Straight Line Directions

(1) Select "Heading".

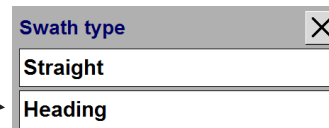

(2) Select blank "Swath Record" box.

(3) Select "New".

(4) If your vehicle is in correct place to begin, select "Mark A".

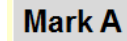

(5) Type in heading degrees - direction of travel for vehicle

0 & 360 = Straight North

90 = Straight East

180 = Straight South

270 = Straight West

You can input any heading from 0 to 360.

(Example: North East - 45 Degrees)

You can also use GPS heading indicator to point vehicle in direction you wish to travel and enter heading that shows in box into box as shown above.

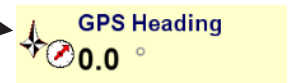
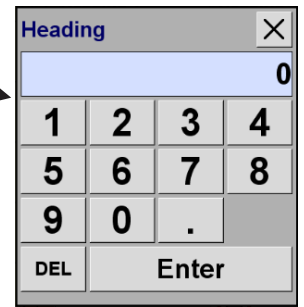

C. Curve Line Directions

(1) Select swath type "Curve".

(2) Select blank "Swath Record" box.

(3) Select "New".

(4) If your vehicle is in correct place to begin, select "Mark A".

(5) Drive entire length of curve and select "Mark B".

We use this for field end rows or around waterways etc.



4. Swath Manage

A. After Generating the Guidance Line

(1) In swath manage box select "Name"

(2) Rename the line so you are able to identify in the future (i.e. East Fence Rows, East West AB, Plant 2012)

This can be done while guidance engaged and while traveling through field.

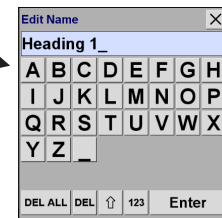
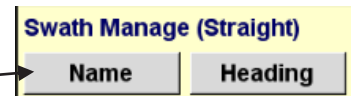

5. Trim - Used to adjust guidance for pull-type implements that do not trail exactly on AB Line.

A. Trim Can Be Adjusted During Operation

(1) Select trim box and move arrows to right or left.

(2) > Arrow means right trim.

(3) < Arrow means left trim.

Right Trim will move tractor to Right Side of AB Line.

Left Trim will move tractor to Left Side of AB Line.

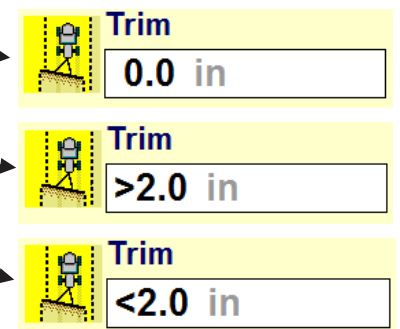

6. Remark - Used to move AB Line a certain number of feet Right or Left of Original.

Display Sees Remark Sitting at Point A looking at Point B

A. To Remark a Line Select "Re-Mark" Box



(1) "Re-Mark" line to the Right "Positive Number".

Always remember sitting in seat of vehicle if vehicle is pointing in direction AB line was created "Looking from Point A to B". If you need to move line Right enter positive number.

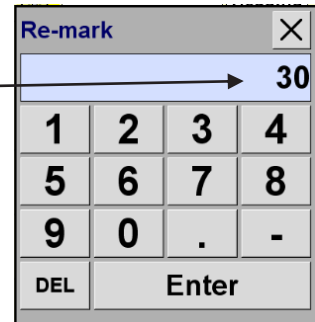

(2) "Re-Mark" line to the Left "Negative Number".

Always remember sitting in seat of vehicle if vehicle is pointing in direction AB Line was created "Looking from Point A to B". If you need to move line Left enter negative number.

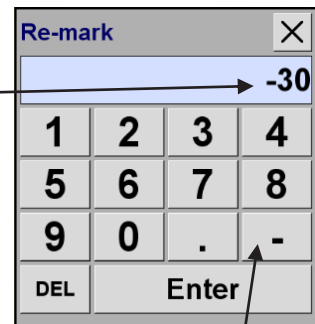

Press Negative Symbol to Make Negative Number

7. Aggressiveness - How Quickly the Vehicle Steers

A. Changing Aggressiveness

(1) Select Aggressiveness box.

(2) Adjust value up or down.

Allows operator to adjust aggressiveness of steering system to match field conditions.

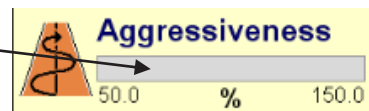

8. Cross Track Error - Offline Distance Between Center Line of Vehicle and AB Line

Allows operator to see on line performance. Displays in inches.

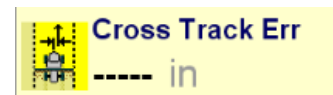

Boundary Recording

Instructions for Creating Field Boundaries

This can be done with or without an implement - easier without implement to be more accurate.
 You either record from centerline of tractor (GPS Antenna) or left / right side of implement.
 It's easiest to do the left or right side as to get close to fences.
 Make an implement that matches the width of tractor.

1. Select "Toolbox" "Impl"

Make implement called Boundary for recording boundaries.
 Make it the width of the tractor or close to that.



2. Select Correct "Grower" "Farm" "Field" on

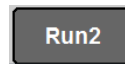

3. Select "Run 5"

If you setup run screens like our reference page it will look like this.

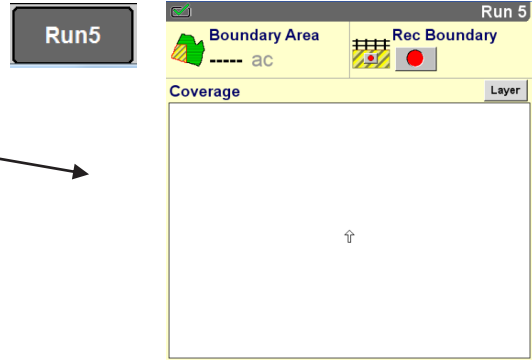

4. Select "Record Boundary"

Best to have vehicle where you want to start.



5. Select "Recording Edge"

"Center" Center Line of Tractor/
 "Left" Left Edge / "Right" Right Edge
 If recording outer field boundary
 leave boundary type "Outer".
 Select "Start".

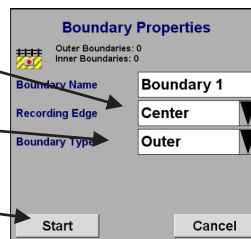

6. Drive Field Boundary

Boundary will complete upon returning to starting point.
To make the fence lines perfectly straight on your boundary you can pause during recording on the straight portions.

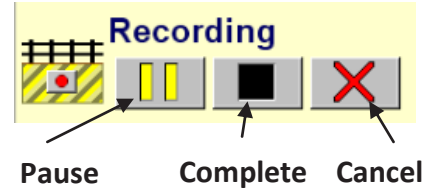

Start Here Traveling Counter Clockwise
If you Start on A portion You Want to Make Straight
Select "Record" then "Pause" When Resume is Hit Again it
will Snap the Line Perfectly Straight Between the Two
Points. Much Like an AB Line.

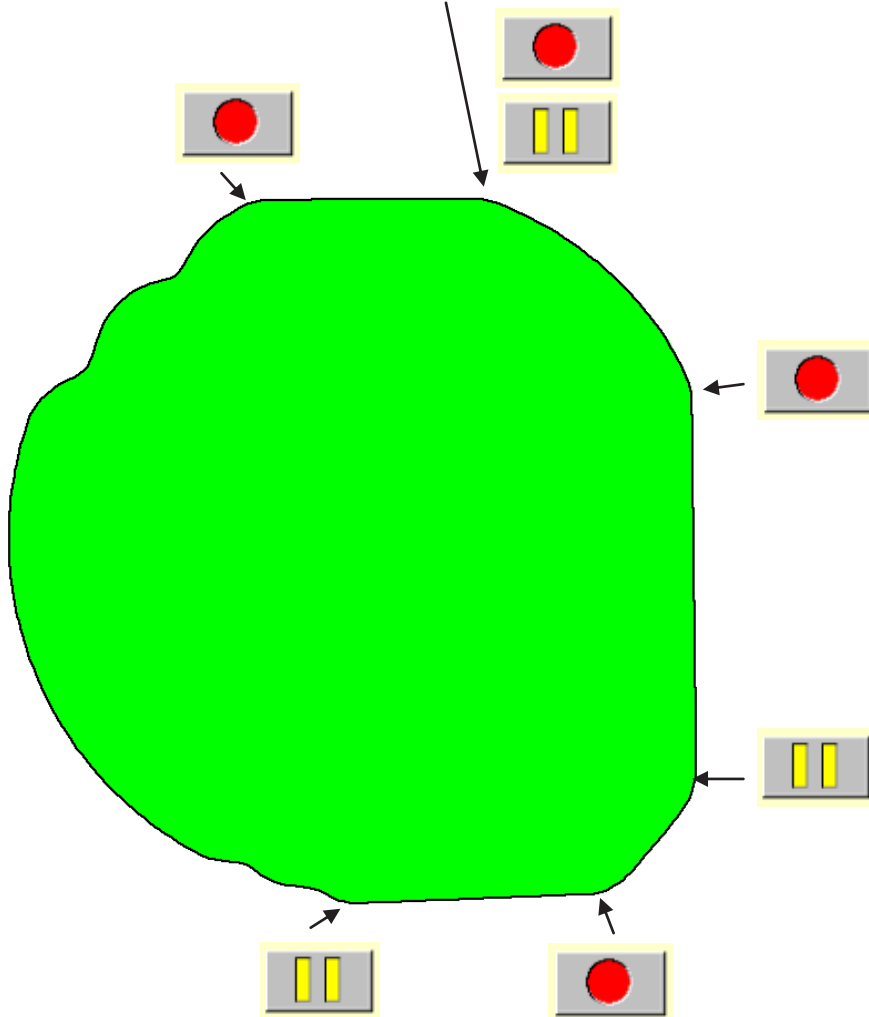

Filtering Crop List

1. Select "Data Management" "Filter"

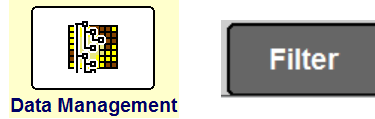

2. Select "Filter Crop List"



3. Crop List Box Appears
Crops with X by them will Appear
In Crop Type Drop Down in Run Screens

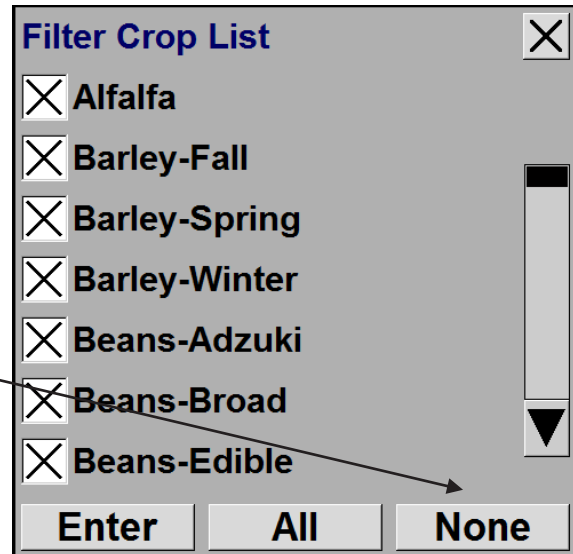

4. Select "None" First

5. Select the Crops You Need
Crops with X will be Kept
These Are Not Erased so At Any Point
You Can Add a Crop if You Missed One

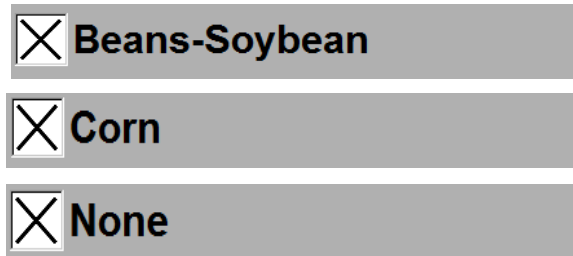

6. Select Enter When You Finish



7. Run Screens Will Now Appear Like This

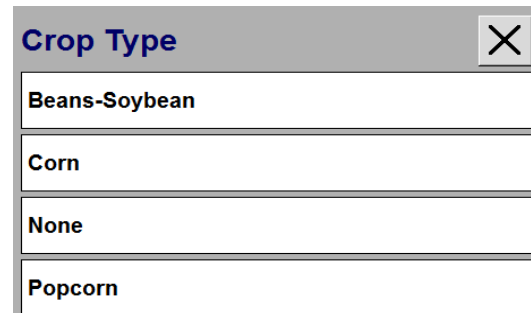

Recommended Layout Screens for Guidance / Tractor

Run Screen
Left Area ▼
Active Step
Engine Power
Slip
Fuel/Area
Fuel/Area,Fld,Avg
Guidance Engage

Run Screen	Number of Windows
Run1 ▼	2 x 5 ▼
Swath Map 2x5	Swath Map 2x5
Swath Map 2x5	Swath Map 2x5
Swath Map 2x5	Swath Map 2x5
Swath Map 2x5	Swath Map 2x5
Swath Map 2x5	Swath Map 2x5

Run Screen	Number of Windows
Run2 ▼	2 x 6 ▼
Grower	Work Condition
Farm	Implement
Field	Operator
Task	Operation Instance
Crop Type	GPS Status
Tag	GPS HDOP

Run Screen	Number of Windows
Run3 ▼	2 x 6 ▼
Swath 1 Record 2x1	Swath 1 Record 2x1
Swath Manage	Swath Select
GPS Heading	Re-mark
GPS Status	Trim
Cross Track Err	Nudge
Aggressiveness	Guidance Engage

Run Screen	Number of Windows
Run4 ▼	2 x 6 ▼
Fuel Level	Slip, Wrk, Avg
Fuel/Area,Fld,Avg	Work Rate
Fuel/Hour	Work Rt,Wrk,Avg
Fuel/Hour,Fld,Avg	Time, Work
Area	Time, Field
Area Season	

Run Screen	Number of Windows
Run5 ▼	2 x 6 ▼
Boundary Area	Boundary Record
Map 2x5	Map 2x5
Map 2x5	Map 2x5
Map 2x5	Map 2x5
Map 2x5	Map 2x5
Map 2x5	Map 2x5

Run Screen	Number of Windows
Run6 ▼	1 x 4 ▼
Engine Hours	
Driveline Hours	
Eng Load,Wrk,Avg	

SECTION 3 - TRACTOR PERFORMANCE

Contents

Magnum 180*340 Full Powershift Multi-Function Armrest.....	38
Automatic Productivity Management (APM).....	40
Magnum 180-380 CVT Tractor MultiControl Armrest.....	41
Settings for Tier 4B Final.....	43
Multi-Function Handle Full Powershift.....	55
Magnum Series III Auto Shift Operation.....	56
Magnum Series III Auto Field Operation.....	57
Magnum Series III Electronic End of Row (EOR).....	58
Magnum Series III Display Icons.....	59

Magnum 180-340 Tractor Full Powershift MultiControl Armrest

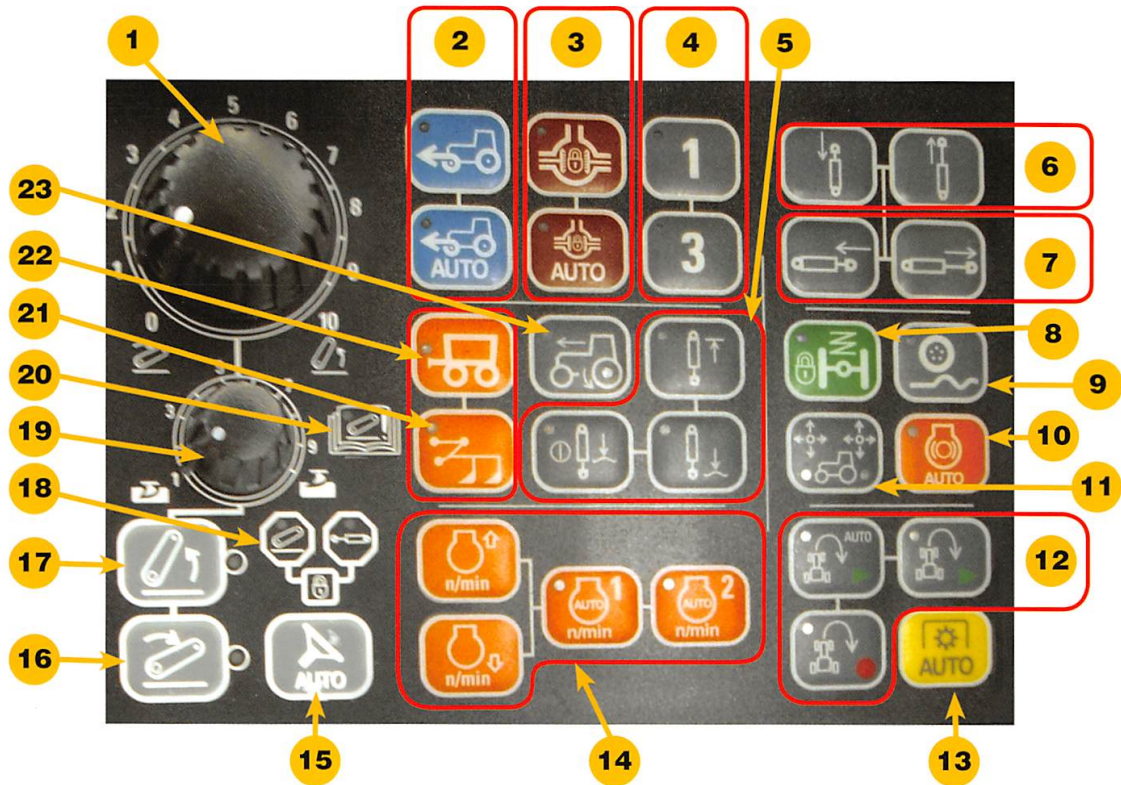

- | | | |
|---|--|---|
| 1 3-Point Hitch Position Control | 9 Ride Control use with 3-Point Hitch | 17 Rear Hitch – Slow Raise |
| 2 Manual & Auto MFD | 10 Engine Brake | 18 Hitch and Hydraulic Lock Indicator |
| 3 Manual & Auto Diff. Lock | 11 Joystick Assignment | 19 3-Point Hitch Draft Load Control |
| 4 Auto Mode Remote Valve #1 & #3 | 12 End-of-Row Functions | 20 Rear Hitch Status Indicator |
| 5 Auto Depth Control System | 13 Auto PTO use with 3-Point Hitch | 21 APM Field Mode |
| 6 Hydraulic Top Link Control | 14 Constant Engine Speed | 22 APM Road Mode |
| 7 Hydraulic Lower Link Control | 15 AutoGuidance Engage | 23 Slip Control use with 3-Point Hitch |
| 8 Suspended Axle Lockout | 16 Rear Hitch – Slow Lower | |

Magnum 180-340 Tractor Full Powershift MultiControl Armrest

Operator Environment – Armrest Controls

Adjustments under the elbow rest

- 1 Set all hydraulic flows and timers
- 2 Set 3-point hitch slip limit
- 3 Adjust 3-point reaction rate
- 4 Adjust 3-point raise limit
- 5 Adjust 3-point hitch draft response

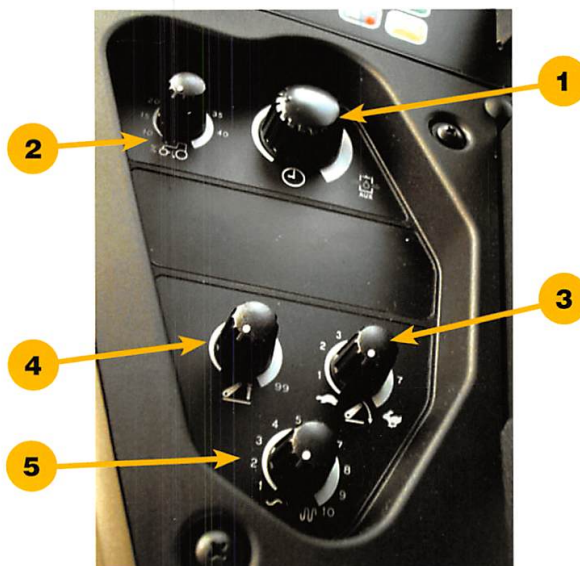

Operator Environment – Multi-Function Handle

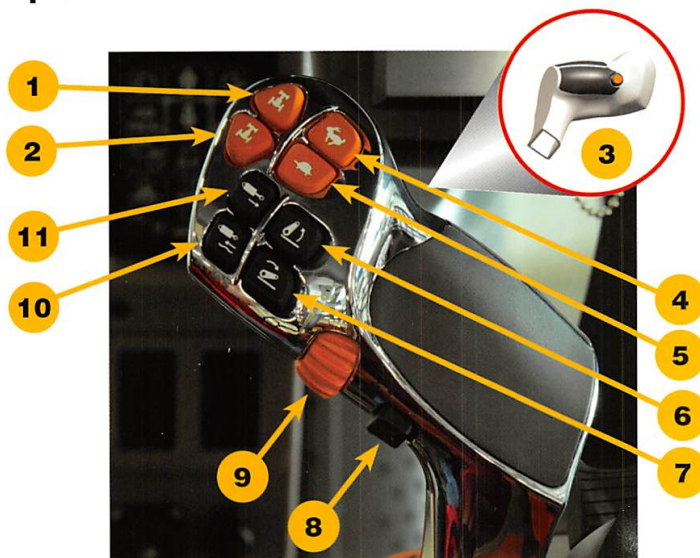

- 1 Right Hand Shuttle – Forward
- 2 Right Hand Shuttle – Reverse
- 3 EHR Float for Remote #1
- 4 Up Shift
- 5 Down Shift
- 6 Rear 3-Pt Hitch – Raise
- 7 Rear 3-Pt Hitch – Lower
- 8 Electronic End-of-Row Function
- 9 APM Target Speed Wheel Increase/Decrease
- 10 Electronic Remote – Retract 1 or 5
- 11 Electronic Remote – Extend 1 or 5

APM Field & Road

The Automatic Productivity Management system can be used to run the tractor at a set speed and allow the engine and transmission to work automatically. There is a FIELD mode and a ROAD mode. The transmission will shift automatically and the engine will adjust the throttle automatically to maintain the desired speed as the load changes. The system has been nicknamed the DIESEL SAVER™ as it can save a lot of fuel.



FIELD Mode Operation

Lock in a new target speed:

1. Drive the tractor at the desired speed.
2. Hold the FIELD button down for about 3 seconds until it beeps.
3. Your target speed will stay in memory until you lock in a new speed.

Turn the FIELD Mode ON:

1. Push and release the FIELD button.
2. The green plow will light up and the handle will now function as a speed lever, move the handle all the way forward to drive the target speed, pull back on the handle to slow down.

NOTE: Once the target speed is set, use the scroll wheel to increased or decreased the target speed on the go. When the tractor is shut off and then started again, the APM field mode will default to the last change made.

ROAD Mode Operation

Turn the ROAD Mode ON:

1. Push and release the ROAD button.
2. The green wagon will light up and the handle will now function as a speed lever, move the handle all the way forward to drive at top speed, pull back on the handle to slow down.

Operation Notes:

- Notice the A-post will display the target speed every time you move the handle.
- When slowing down on the ends just pull the handle back a little bit and not a lot.
- Set the sensitivity to minimize the shifting that occurs in the FIELD Mode, and set the start up gear for the ROAD mode.

Set FIELD APM SENSITIVITY & ROAD APM START UP GEAR:

NOTE: The following procedure is not available on Magnum 180-220.

1. Start the Engine and hold the PROG button.
 2. Use arrow keys to Select TCU using arrow key, push PROG.
 3. Select ETC, push PROG.
 4. Select TRANS SETUP, push PROG.
 5. Select SET APM SNTV, push PROG.
 6. The default is 100%, recommend setting to 65-75% for Magnum and Steiger, push PROG.
 7. Select SET AUTO LIMIT, push PROG.
 8. The default is 4th for Steiger and 7th for Magnum – When driving in the ROAD mode, this is the gear it will start from at a stop. Set to the desired start gear and Push PROG.
 9. Push RESET to exit back to normal operating screens.
- FOR TRACTORS WITH AFS Pro 700 THESE SETTINGS CAN BE DONE IN TOOLBOX, UNDER TRACTOR TAB.

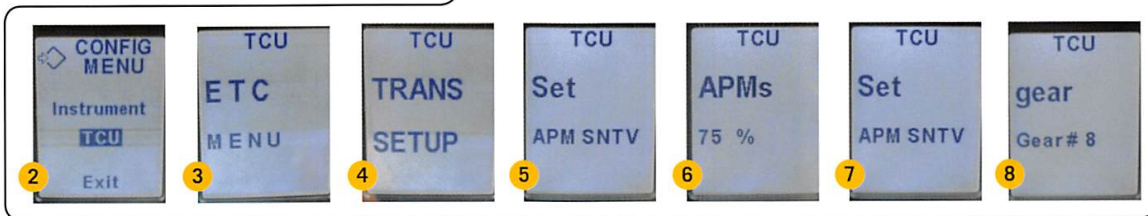

Magnum 180-380 CVT Tractor MultiControl Armrest

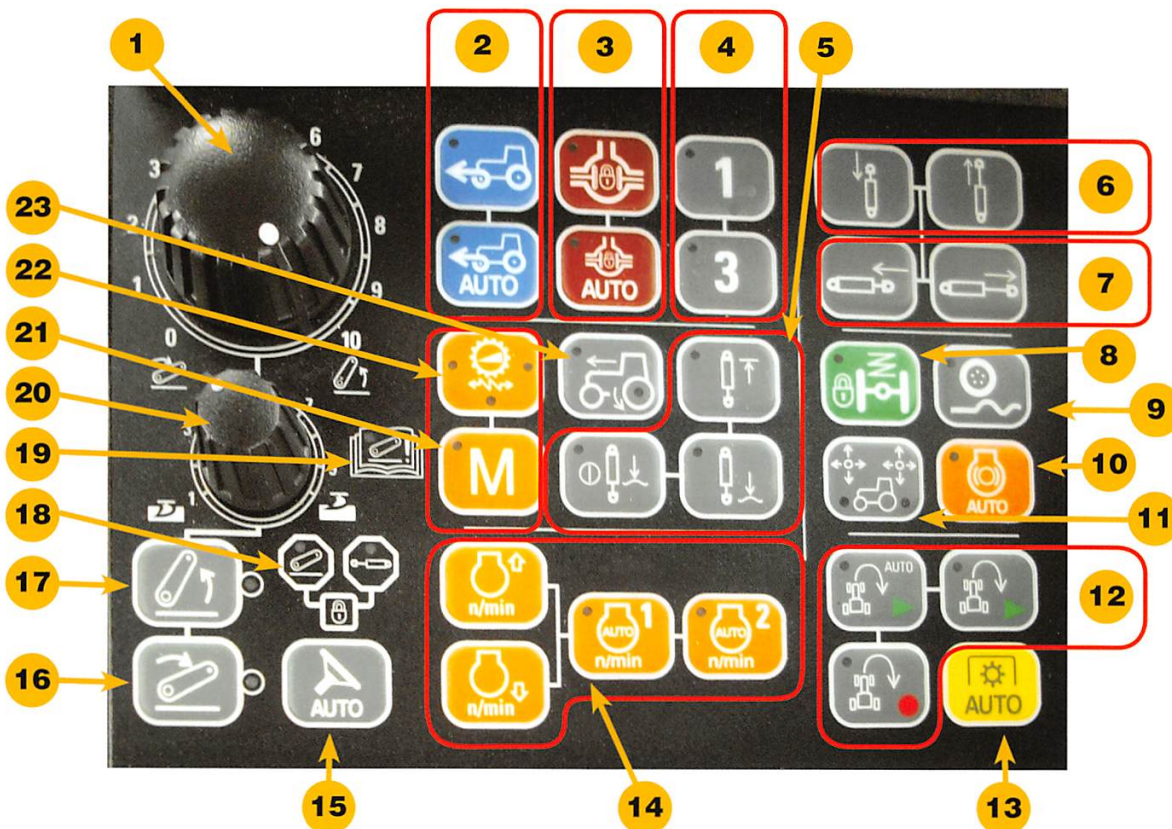

- | | | |
|---|--|---|
| 1 3-Point Hitch Position Control | 9 Ride Control use with 3-Point Hitch | 18 Hitch and Hydraulic Lock Indicator |
| 2 Manual & Auto MFD | 10 Engine Brake | 19 Rear Hitch Status Indicator |
| 3 Manual & Auto Diff. Lock | 11 Joystick Assignment | 20 3-Point Hitch Draft Load Control |
| 4 Auto Mode Remote Valve #1 & #3 | 12 End-of-Row Functions | 21 Manual Mode |
| 5 Auto Depth Control System | 13 Auto PTO use with 3-Point Hitch | 22 Aggressiveness / Responsiveness of the transmission |
| 6 Hydraulic Top Link Control | 14 Constant Engine Speed | 23 Slip Control use with 3-Point Hitch |
| 7 Hydraulic Lower Link Control | 15 AutoGuidance Engage | |
| 8 Suspended Axle Lockout | 16 Rear Hitch – Slow Lower | |
| | 17 Rear Hitch – Slow Raise | |

Magnum 180-380 CVT Tractor MultiControl Armrest

Operator Environment – Armrest Controls

Adjustments under the elbow rest

- 1 Set all hydraulic flows and timers
- 2 Set 3-point hitch slip limit
- 3 Adjust 3-point reaction rate
- 4 Adjust 3-point raise limit
- 5 Adjust 3-point hitch draft response

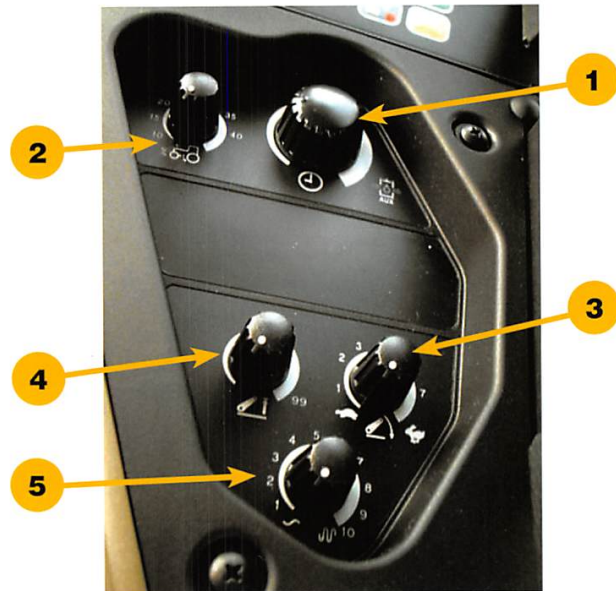

Operator Environment – Multi-Function Handle

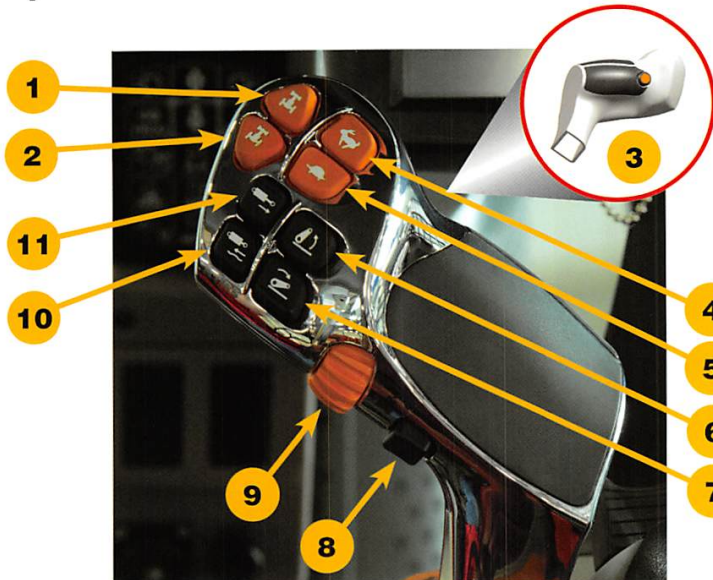

- 1 Right Hand Shuttle – Forward
- 2 Right Hand Shuttle – Reverse
- 3 EHR Float for Remote #1
- 4 Up Shift
- 5 Down Shift
- 6 Rear 3-Pt Hitch – Raise
- 7 Rear 3-Pt Hitch – Lower
- 8 Electronic End-of-Row Function
- 9 APM Target Speed Wheel Increase/Decrease
- 10 Electronic Remote – Retract 1 or 5
- 11 Electronic Remote – Extend 1 or 5

Programmable Target Ground Speed

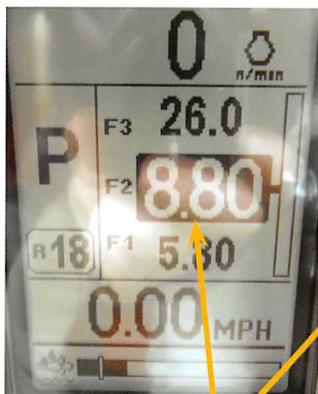

Depress the Rabbit or the Turtle buttons to select which target speed set point that will be used for current operation. Target speeds can be set differently for forward or reverse operation. Three settings are available for forward and three for reverse.

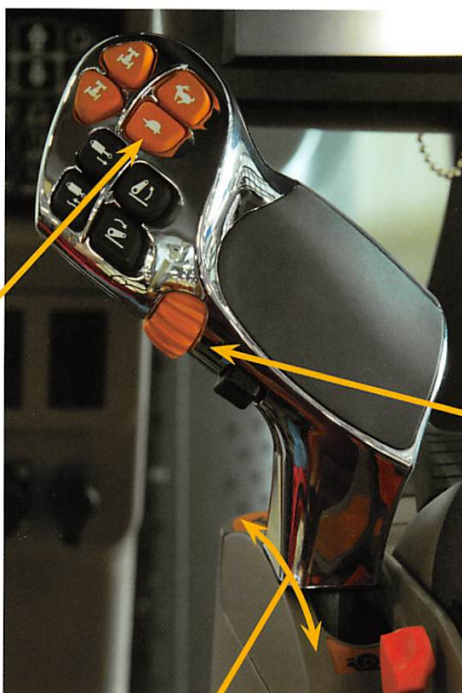

The MultiFunction handle sets the speed at which the tractor travels. At fully rearward position (towards the operator), the tractor is stationary. At full forward position, the speed of the tractor is limited to the F1, F2, or F3 current target speed displayed. The operator can use the rabbit and turtle buttons to select a different target speed with the MultiFunction handle in any position. The operator can select forward or reverse movements with the handle in any position.



Use the thumb scroll wheel to adjust the target speed set points. These can be adjusted stationary or while moving forward. Turning the thumb wheel faster changes the speed reading on the display in larger increments. Turning the scroll wheel slower allows for small adjustments.

To set the reverse shuttle, move the tractor slightly forward and then shuttle to reverse and stop the tractor. At this point the R1, R2 and R3 reverse speeds can be set. Use the scroll wheel to adjust the target speed set points. These speeds can be adjusted stationary or while moving forward.

Setting the Throttle

Magnum™ tractors with the CVT transmission are equipped with two throttles (known also as split throttles) located on the side of the armrest. In Automatic Mode, the two throttles set the range that the engine RPM can automatically adjust according to load. This will allow the tractor to throttle back in light load applications to save fuel. The engine can also accelerate as required in heavier load conditions. The left lever (the one closest to the operator) will set the minimum throttle setting. The right lever sets the maximum engine RPM.



When operating in road transport and in light load applications, set the throttle lever fully apart, to achieve the maximum fuel savings.



When operating in PTO applications, set the throttle levers together to maintain constant PTO speed.



In tillage applications set the right throttle to full forward to achieve maximum engine rpm. The set the left throttle to mid position to prevent the engine from idling when turning on the headlands.

There are three levels of CVT transmission responsiveness available. The three status lamps on the rate control button indicate which setting is currently active. A single lamp illuminated for minimum acceleration rate, two lamps for medium acceleration, three lamps for maximum acceleration. By depressing the touch pad switch, the rate of acceleration changes. Each time the switch is depressed the number of illuminated lights will change.



Hydraulic Lock Switch

- Use the Hydraulic Lock switch to lock out the Hitch or the Electro Hydraulic Remote valves (E.H.R.).
- This switch can be used during transport to prevent unintended movement of an implement, or in the field to prevent unintended movement of the hitch.
- Use the “Stop sign” indicator lights to see what is locked.

3 Position LOCK switch:

1. Hitch and EHR work
2. Hitch locked
3. Hitch and EHR locked

NOTE: The Hydraulic Lock Switch is located on the right-hand window console.

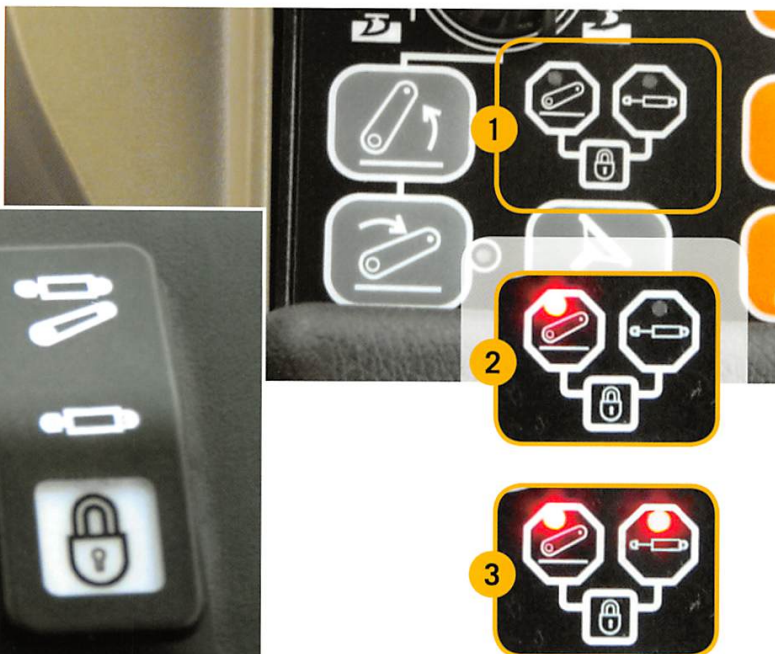

Auto MFD & Difflock

For **DRAWBAR** implements, **LOCK THE HITCH** using the **LOCK SWITCH**

IN THE AUTO MODE the MFD and Difflock will stay ON unless:

1. The steering wheel is turned left or right off center
2. The right or left brake is depressed
3. The vehicle exceeds 12 mph
4. Using Auto MFD and Difflock with the rear 3-point hitch:
Lowering the 3-pt hitch will activate the Auto MFD and Difflock
Raising the 3-pt will deactivate the Auto MFD and Difflock
5. If the 3-pt hitch is not being used, the Hydraulic lock switch must be in the center position, so as to not lock out the hydraulic system.

If you do not want the MFD or Difflock to turn OFF with the steering wheel, then do not use the AUTO function.



Setting the Performance Screen

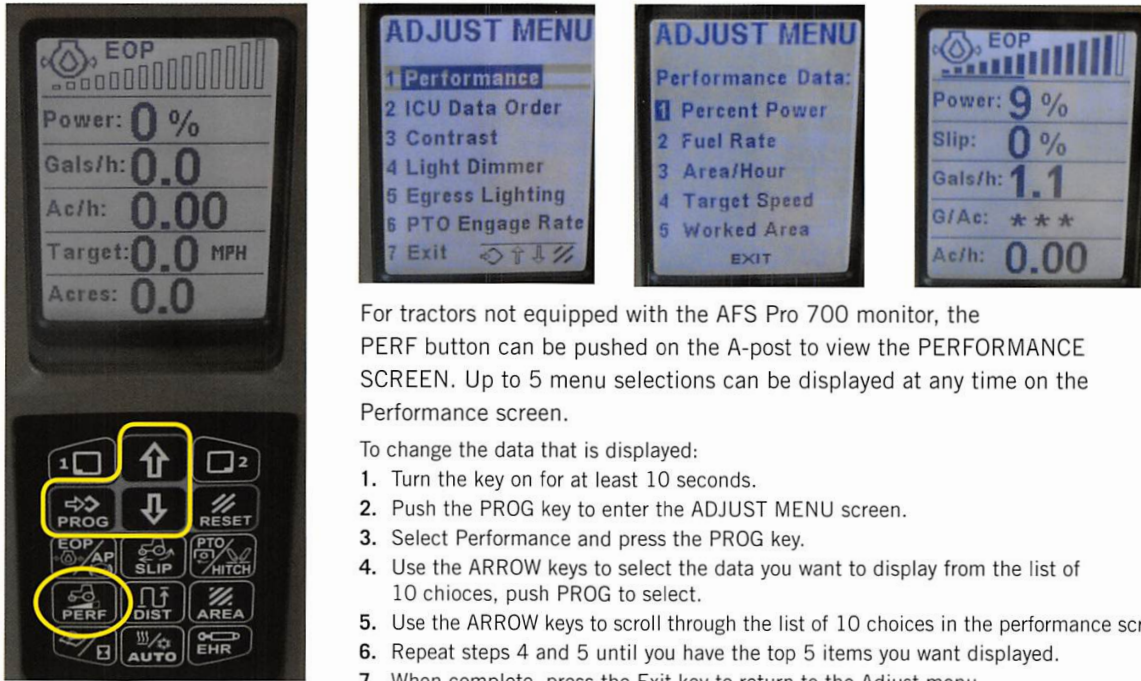

For tractors not equipped with the AFS Pro 700 monitor, the PERF button can be pushed on the A-post to view the PERFORMANCE SCREEN. Up to 5 menu selections can be displayed at any time on the Performance screen.

To change the data that is displayed:

1. Turn the key on for at least 10 seconds.
2. Push the PROG key to enter the ADJUST MENU screen.
3. Select Performance and press the PROG key.
4. Use the ARROW keys to select the data you want to display from the list of 10 choices, push PROG to select.
5. Use the ARROW keys to scroll through the list of 10 choices in the performance screen.
6. Repeat steps 4 and 5 until you have the top 5 items you want displayed.
7. When complete, press the Exit key to return to the Adjust menu. Press the Exit key again to return to normal operating screens.

Setting the Egress Courtesy Lights



The Egress Lighting can be set to turn the tractor lights on for up to 2 minutes so that you do not need to exit the tractor in the dark. To set:

1. Turn the key on for at least 10 seconds.
2. Push the PROG key to enter the ADJUST MENU.
3. Select Egress Lighting and press PROG.
4. Then select OFF, ON, or TIMER and press program
5. Use the ARROW keys to select NIGHT and press PROG.
6. Use the ARROW keys to change the timer setting, it can be set up to 120 seconds, push PROG.
NOTE: The TIMER default is 5 seconds, which is set at the factory.
7. Press the Exit key to return to normal operating screens.



Acre Counter & Implement Status



The Implement Width must be set for accurate display of the Acre Counter, Acres per hour, and Gallons per Acre. The Acre Counter can also be set to automatically activate when the implement is lowered.

1. Push the AREA button, this will pull up the Area screen.
2. Push the AREA button again, use the arrow to set the implement width.
3. **For Performance Monitor:** From the area screen, press the area key twice to access the hitch or remote valve selection screen. Once there, press the up or down arrow to make the selection. Press the program key to save the selection and return to the normal operation screens.
For AFS Pro 700 Display: To access the Hitch or EHR for the implement, select the implement tab to implement type and the screen listing the hitch and the number of remotes on the tractor, and make your selection.
4. Push the AREA button again to return to area screen.
5. Push the "2" button to toggle between OFF / ON / AUTO.
6. In AUTO acres will be counted when the implement is lowered, and suspended when the implement is raised, as shown by the arrow.
7. To RESET acres, push the "1" button, then push and hold the "1" button until the acres reset to 0.

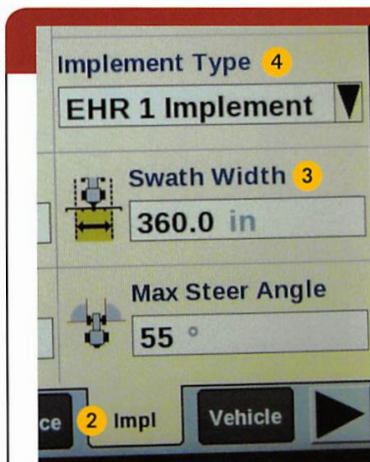

For Tractors Equipped with AFS Pro 700

1. From the main screen select TOOLBOX
 2. Select the "Impl" tab
 3. Set the implement width
 4. Set the implement type
- The status of the implement will be shown by an arrow in the upper left corner of the screen.
 - The status will automatically activate the Work Control, which triggers the Coverage Map, and Acre Counter.

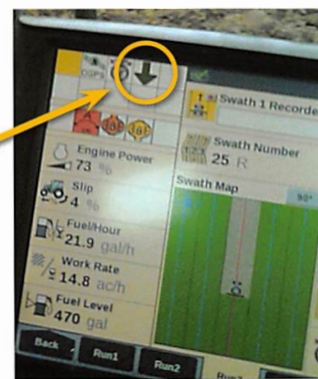
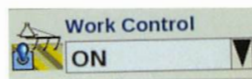

Radar Quick Check

NOTE: The following procedure is not available on Magnum 180-240 tractors.

- For tractors equipped with radar, verify that it is properly calibrated.
- Drive the tractor in a straight line at a steady 5 mph, with no load, the slip reading should be 0%. 1% may show occasionally.
- If the slip reading is NOT 0% when the wheels are NOT slipping, then follow the procedure below.

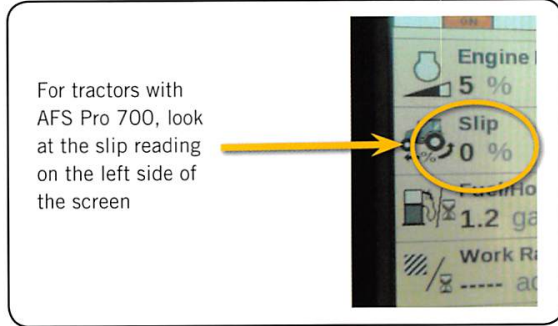
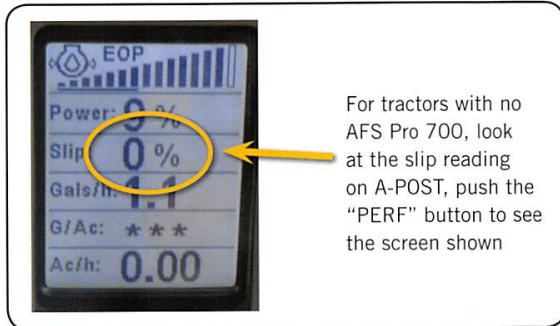

NOTE: The following steps can not be preformed on Magnum 180-240 tractors.

1. Turn the key on, push and hold the PROG, the CONFIG menu will appear.
2. Select TCU using the arrow key, push PROG.
3. Push the down arrow until ETC is shown, push PROG.
4. Push the down arrow until TRANS RADAR is shown, push PROG.
5. Select RADAR MANUAL with the PROG key.
6. The factory default is typically 27.46. Use the down arrow and turn it down to about 26.00, push RESET.
7. Drive the tractor and verify the slippage. If the slippage is still off, repeat the steps until it is zero'd out. The radar setting will typically be somewhere between 25.00 to 26.00.

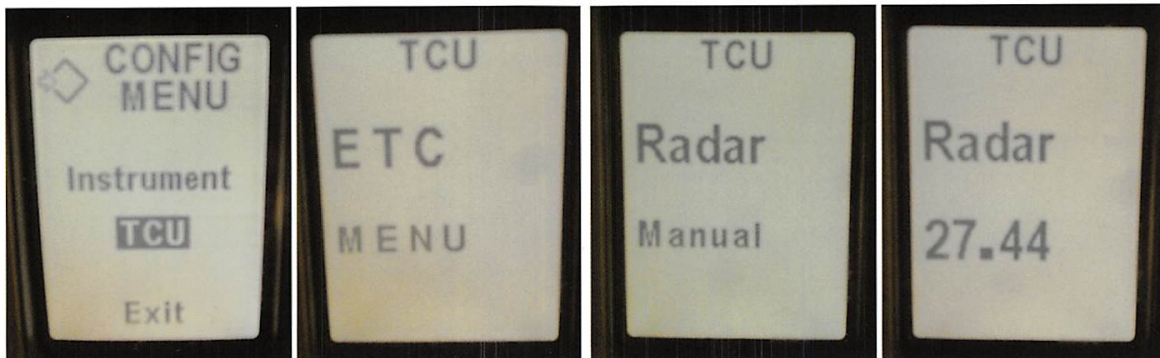
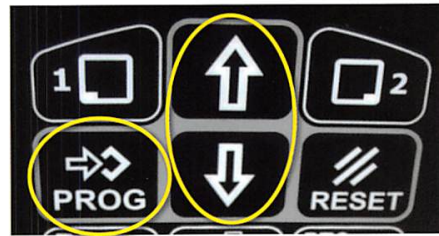

In some cases the tire radius setting should also be verified per the Operator's Manual.

If the radar is not set properly this will cause several issues, which includes: Slippage is not accurate, field speeds will be several tenths too slow, road speeds will show several mph slow, APM will never reach target speed, acre counter is wrong, gallons per acre is wrong, etc.

Setting the Remotes

The EHR remote valves should always be set so that the tractor hydraulic system is not working any harder than it needs to. This will save horsepower, fuel, reduce fatigue on hydraulic components, and reduce heat and noise. Proper setting includes turning the flow controls down so they are only as high as they need to be, and proper setting of the timers. Each remote value can be set independently and the raising and lowering is independent for each remote.



- Push the EHR key to display a summary screen of the remote valves on the A-Post
- If the tractor has more than 4 remotes, push the EHR key again to display the remaining remotes

UNDERSTANDING THE SUMMARY SCREEN

- A.** Remote valve number.
- B.** Oil flow percentage for the retract circuit.
- C.** Oil flow percentage for the extend circuit.
- D.** Timer setting for the extend circuit in seconds.
- E.** Timer setting for the retract circuit in seconds.
- F.** Timer control on (automatic) or off (manual) control.
- G.** Current status of the control: neutral, float, extend, retract, motor, locked.

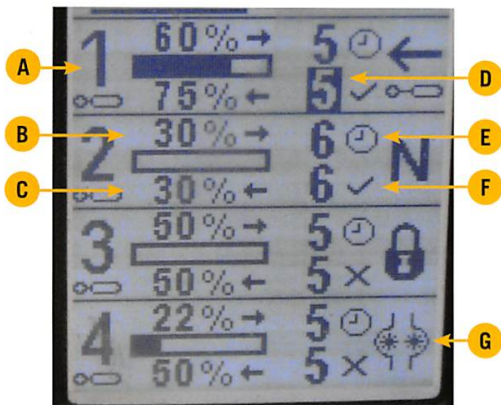

MAKING EHR ADJUSTMENTS

1. Rotate the SELECTOR knob on the armrest to highlight the EHR valve you wish to set.
2. Tap on the SELECTOR (this is also a button).
3. Rotating the SELECTOR to the value you wish to change.
4. Tap on SELECTOR and rotate to change the value.

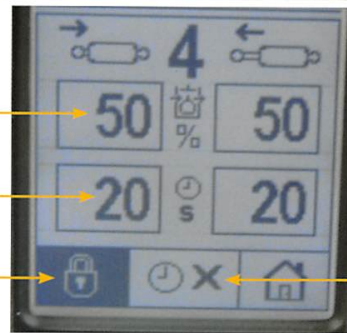

SETUP SCREEN ADJUSTMENTS:

- A.** FLOW RATE independent for retract or extend.
- B.** TIMER setting for retract and extend.
- C.** Timer control ON or OFF.
- D.** Valve lock or unlock.

LEARN MODE FOR SETTING TIMERS: Start with the Timer OFF, hold the button (A) until the light starts flashing (B), fully retract and then extend the function – the timer will set itself automatically.

MOTOR MODE FOR HYDRAULIC MOTORS: Start with the Timer OFF, activate the motor by pushing the lever to the forward detent, then push the button (C), notice motor light (D) turns on and the motor symbol appears next to that remote on the screen. Normally a motor is shut off by going to float, but in the motor mode if the lever is accidentally pulled to neutral, the valve will float and allow the motor to slow down gradually.

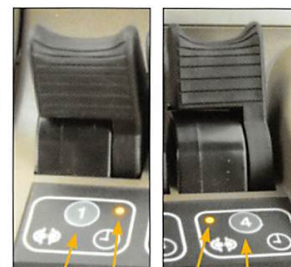

Multi-Function Handle

The multifunction can be used for simple or advanced applications with one comfortable and convenient place to lay your hand.

FORWARD REVERSE SHUTTLE

Forward and reverse shuttle is simply pushing the forward or reverse buttons on the MultiFunction handle.

TARGET SPEEDS

Use the rabbit and turtle buttons to set up to three programmable target ground speed set points.

HITCH RAISE LOWER

If you are NOT using the hitch then lock it out with the LOCK SWITCH – this will prevent unintended movement.



AUTOGUIDANCE ENGAGE

Autoguidance engage is factory default to the End of Row button on the MultiFunction Handle starting with the model year 2015 Magnum tractor production.

Programmable END OF ROW

To program the GUIDANCE ENGAGE into the EOR, start with Engine running:

1. Push the Record Button.
2. Push the Guidance Engage button.
3. Push the Record button again.
4. Turn the End of Row Function ON by pushing the Play Auto. This step is necessary every time the engine is started.

Tractor must be moving for the EOR to work.

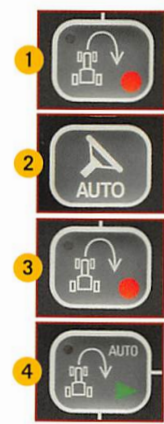

REMOTE VALVE RAISE LOWER

- Controls the EHR #1, (or EHR #5 if equipped).
- The EHR#1 Lever must be in neutral or the buttons on the handle will not work.
- With TIMER turned ON simply push and release the raise or lower all the way up or automatically.
- With TIMER turned OFF the raise or lower buttons are manual, and they must be held to keep the valve active.

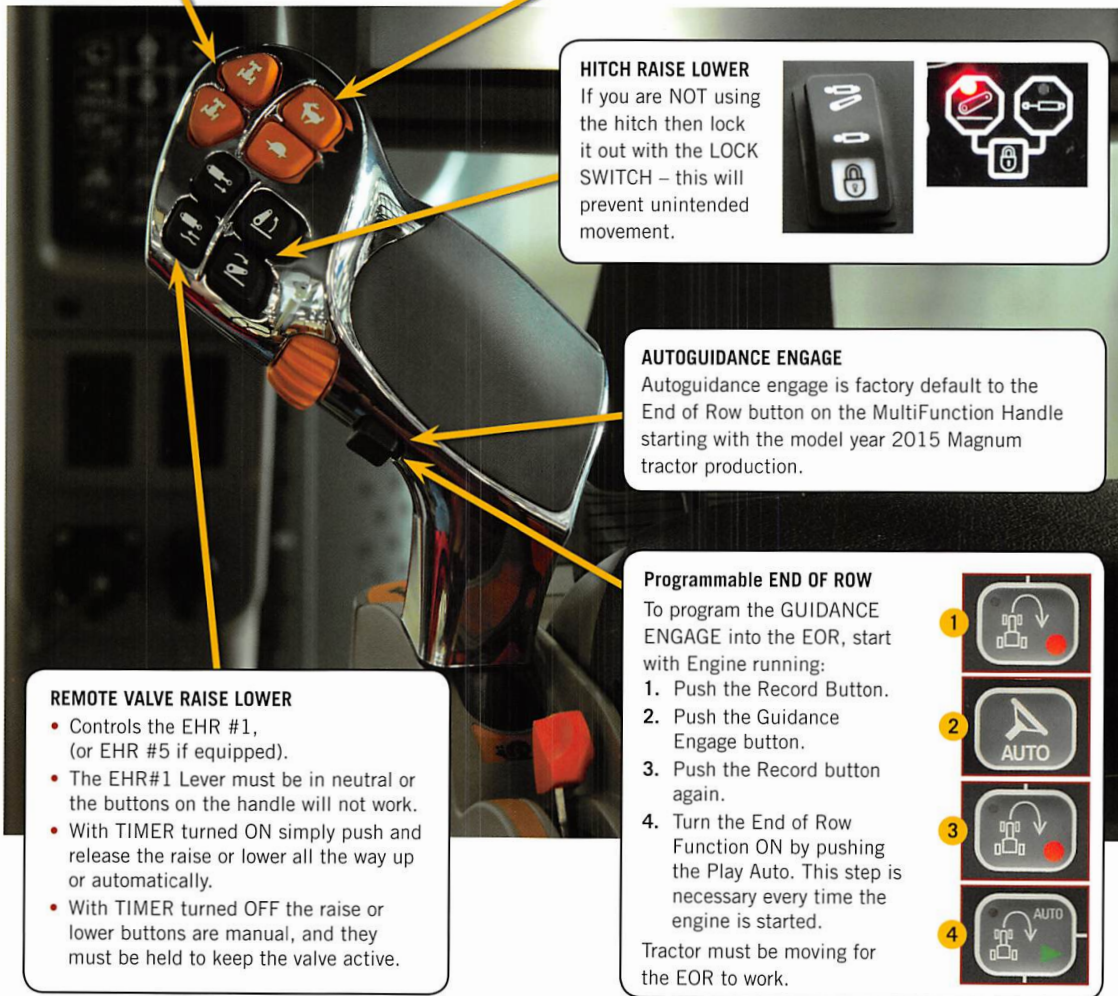

Programming End of Row

The End of Row (EOR) System allows the operator to repeat a sequence of actions on a headland turn by using one button. Up to 30 steps can be recorded, including gear shifts, throttle, remotes, hitch, Difflock, MFD, engage AutoGuidance. A sequence can be recorded sitting still or moving, but the tractor must be moving to Playback.

RECORDING A SEQUENCE

1. Press the EOR Record button momentarily (Red light will begin flashing).
2. Perform the first part of the sequence (Example: downshift gears then raise the implement).
Note: Magnum 180-240 and Puma 185-240, press the step switch first to start recording and engine RPM must be above 1000.
3. Press the EOR Step Button to pause.
4. Press the EOR Step Button to un-pause.
5. Perform your second sequence (Example: Engage AutoGuidance, lower implement, shift to field gear).
6. Press the EOR Record button to save.



EOR Function Buttons

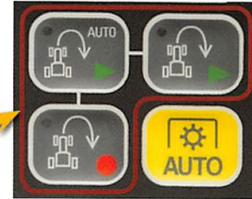

PLAYBACK — Auto Mode

1. Press the EOR Play Auto button to turn on the Auto Mode (Note: Green light will turn on).
2. Push the EOR Step button (tractor must be moving).
3. The first part of the sequence will play back the way it was recorded, then it will Pause and wait for the step switch to be pushed again.
4. Push the EOR Step button to start the second part of the sequence.
5. To disable the EOR system press the EOR Auto play back button.



PLAYBACK — Manual Mode

1. Press the EOR Play Manual button to turn on the Manual Mode (Note: Green light will turn on).
2. Push the EOR Step button to manually step through each function in the recording (tractor must be moving) – Note that if a pause is inserted during the recording, the Step button must be pushed once to advance through the pause.
3. To disable the EOR system press the EOR Play Manual button.



3-Point Hitch

When operating a Magnum™ tractor using the 3-point hitch, draft sensitivity control and hitch draft load control should be properly set for maximum hitch performance.

NOTE: Draft control will automatically lift/lower to the lowest set point of the 3-pt hitch to maintain a constant load.

1. Set the draft sensitivity control (1) to adjust the hitch system to the sensitivity changes in draft load. Rotate the control knob clockwise to increase sensitivity, counter clockwise to decrease sensitivity.
2. Set the hitch draft load control (2) to the desired load to be placed on the tractor to maintain a constant implement depth. Rotate the control counter clockwise to increase the desired draft load and clockwise to decrease the draft load.

NOTE: By turning the control (1) fully counter clockwise will disable the draft load compensation, the 3-point hitch system will be control by the position control only.

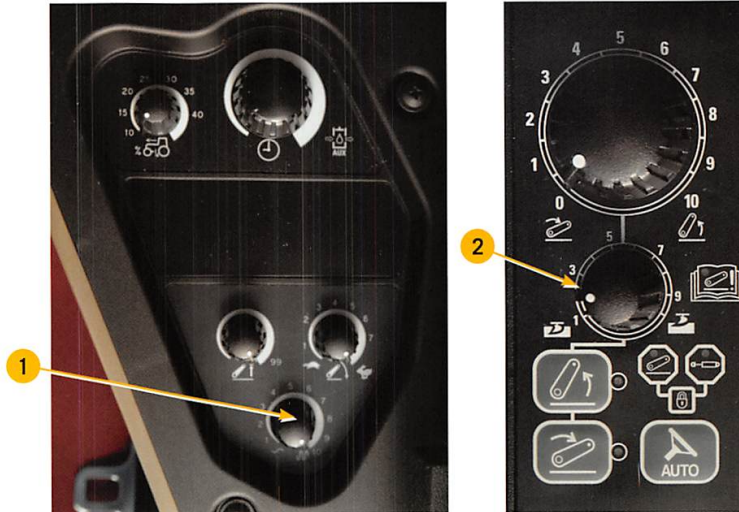

Slip Limit Control Setting

1. Set the slip limit control (1) to the threshold value above which the hitch will raise an implement until the wheel slippage returns to the set level. Rotate the knob clockwise to increase the slip limit value and counter clockwise to decrease the slip limit value.
NOTE: The tractor must be equipped with true ground speed radar in order for the slip limit setting to work.
2. Press the slip limit control (2) to activate the slip system. An amber light will be illuminated. The lamp to the rear will illuminate when the hitch is adjusted to limit rear wheel slippage.



Fault Code Troubleshoot

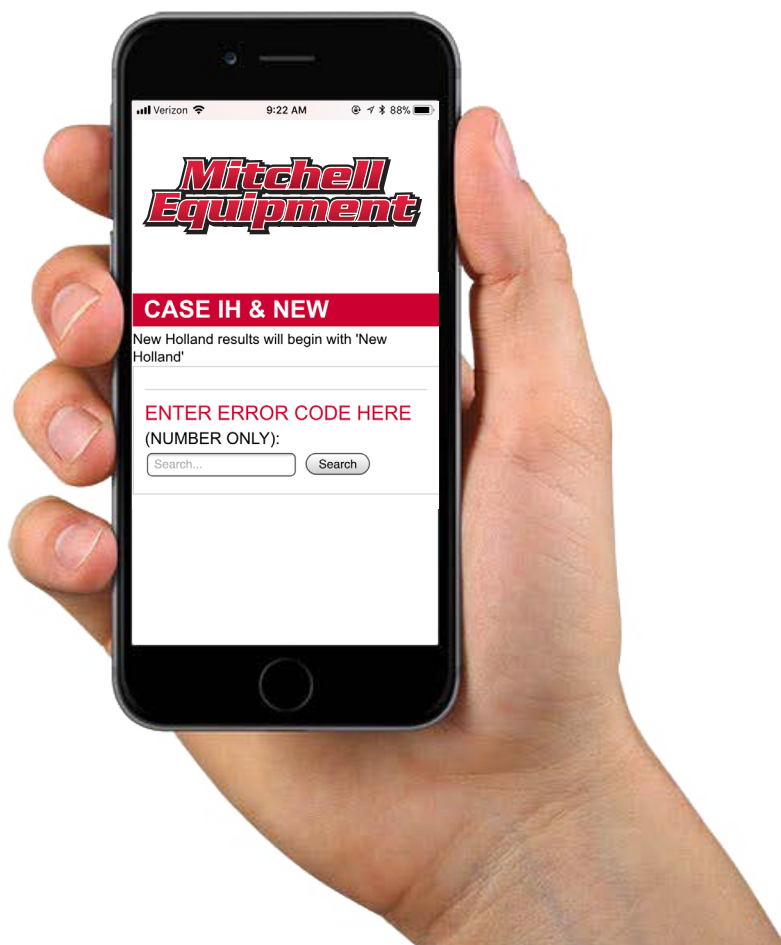

www.MitchellEquip.com

Visit www.MitchellEquip.com to enter your fault code.

Automatic Productivity Management (APM) controls

Use the Automatic Productivity Management (APM) controls to select APM road or APM field operation.



Press and release the APM road button to toggle this feature on and off.

The lamp on the control illuminates when APM road is active; and the APM road icon displays on the tractor instrumentation.



Press and release the APM field button to toggle this feature on and off.

The lamp on the control illuminates when APM field is active; and the APM field icon displays on the tractor instrumentation.

When APM is active, pressing either control turns off APM operation.

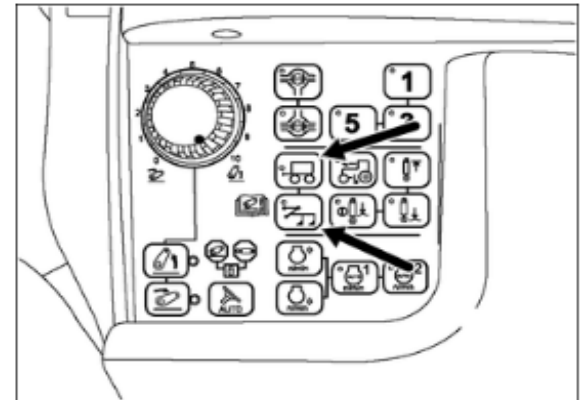

RCPH10FWD045BAG 8

Constant Engine Speed controls

Two different engine RPM values can be saved and used to perform field operations at a constant engine speed.



Press the set point increase button to increase the stored RPM value for the active control: set point 1 or set point 2.



Press the set point decrease button to decrease the stored RPM value for the active control: set point 1 or set point 2.



Press and release the set point 1 button to toggle constant engine speed on or off with its saved set point. The lamp is on when active.

Press and hold the set point 1 button for two seconds to store the current engine RPM as set point 1.

An audible beep sounds when the current RPM value is stored.



Press and release the set point 2 button to toggle constant engine speed on or off with its saved set point. The lamp is on when active.

Press and hold the set point 2 button for two seconds to store the current engine RPM as set point 2.

An audible beep sounds when the current RPM value is stored.

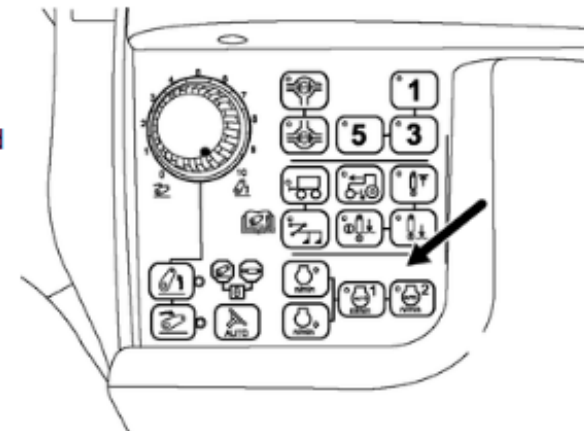

RCPH10FWD045BAG 12

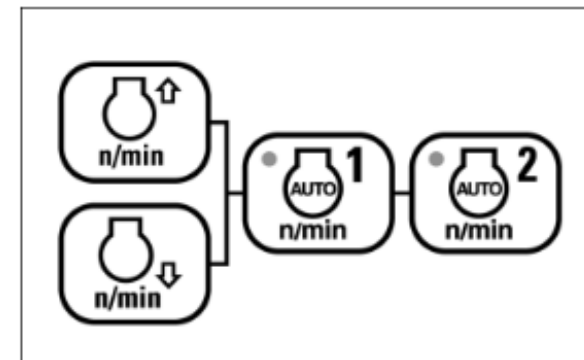

RCIL09CCH003AAA 13

Multi-Function Handle Full Powershift

Gear selection buttons

Use the gear selection buttons on the handle to upshift or downshift the transmission while the tractor is travelling.



Press and release the UPSHIFT button to shift the transmission to the next higher gear. Press and hold the upshift button to shift up one gear every second.



Press and release the DOWNSHIFT button to shift the transmission to the next lower gear. Press and hold the downshift button to shift down one gear every second.

When the tractor is in Park or Neutral, the gear selection buttons only change the forward gears, not the reverse gears.

When in forward gears 4 through 13, the transmission will automatically skip shift two gears at a time with each press of the upshift or downshift buttons. If single shifts are desired, you must also press the second function button in conjunction with the upshift or downshift buttons.

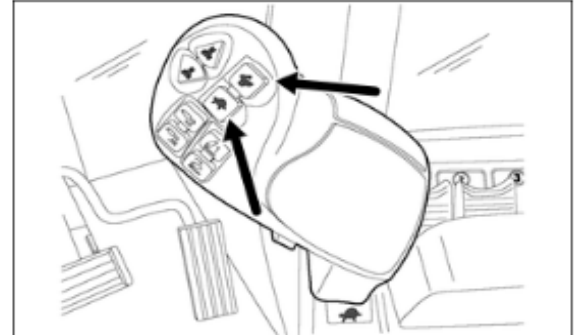

RCPH09CCH267AAB 4

Shuttle shift buttons

Two convenient buttons on the multi function handle are useful for selecting forward or reverse direction of travel.

The forward (1) and reverse (2) shuttle shift buttons must be used in conjunction with the second function button (3) which acts as a shuttle lock button in this circumstance.

NOTE: Initial drive direction must always be selected using the transmission control lever. Subsequent direction changes may be made with the buttons on the multi function handle.



Depress and hold the second function button (3) and then press the forward button (1) to engage forward drive. Before attempting another direction change, release and then press the second function button again.



Depress and hold the second function button (3) and then press the reverse button (2) to engage reverse drive. Before attempting another direction change, release and then press the second function button again.

A warning "beep" sounds if the reverse button is depressed when going forward or if the forward button is depressed when going in reverse without depressing the second function button.

If both buttons are inadvertently pressed at the same time, the tractor will come to a stop. Neutral (N) displays on the upper display and a warning "beep" sounds.

To resume travelling, move the shuttle lever to the forward or reverse position.

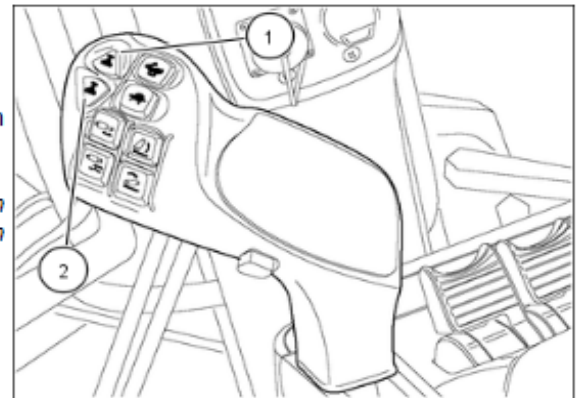

RCPH10FWD104BAG 2

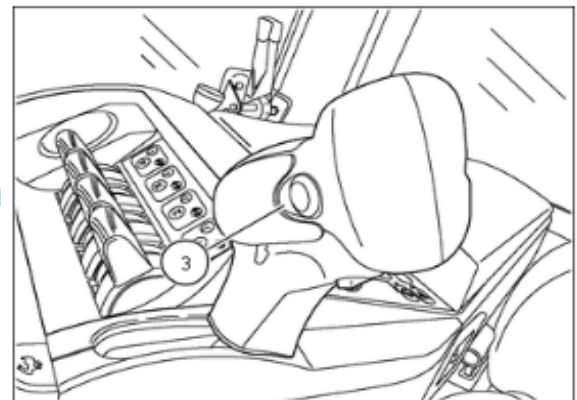

RCPH10FWD105BAG 3

Magnum Series III—Auto Shift Operation

The Auto shift feature permits the tractor to automatically downshift as required to maintain engine speed/torque in Auto Field Operation (AFO) or select transmission gears based largely on throttle input in Auto Road Operation (ARO).

NOTE: *Auto shift does not function in creeper or reverse gears.*

The two modes of operation for Auto shift are:

- Auto Field Operation (AFO) which may be operated in gears 1 through 14.
- Auto Road Operation (ARO) which may be operated in gears 6 through 18 (19 if equipped).

There is no automatic transition between Auto Field Operation and Auto Road Operation. You must exit the current mode of operation to enter the alternate mode.

Auto Field Operation (AFO)

Auto Field Operation is intended primarily for tillage applications or where maintaining engine speed/torque under changing load conditions is accomplished by changing transmission speed. When the bottom of the Auto shift switch is depressed, the Auto shift Icon and the Auto Field Operation icon displays on the instrumentation cluster.

Auto Field Operation is suspended (no automatic shifting occurs, but the mode is not exited) under the following conditions:

- The inching pedal is depressed.
- The hitch UP/DOWN switch is in the UP position
- The transmission control lever is in the NEUTRAL or REVERSE position.
- The UP switch is pressed.
- The Programmable UP/DOWN Shift switch is pressed.
- The Electronic End Of Row Step switch is pressed.
- When the operator leaves the tractor seat. When Auto Field Operation is suspended, the Autoshift icon flashes on the instrumentation cluster. When the condition is removed, automatic shifting resumes and the icon displays steadily.

Auto Field Operation is excited when:

- The bottom of the Auto shift switch is pressed.
- When the operator leaves the tractor seat and the transmission control lever is in the Reverse or Park position.
- Using the upshift selector to select 15th gear. When Auto Field Operation is exited, the Auto shift and AFO icon no longer displays on the instrumentation cluster.

Magnum Series III-Turning Auto Field Operation-ON

Auto Field Operation is intended primarily for tillage applications or where maintaining engine speed/torque under changing load conditions is accomplished by changing transmission speed.

Automatic gear selection depends on transmission output shaft speed, current gear engaged, and the engine torque (electronically controlled engines only) required to maintain tractor performance under varying load conditions. These shift characteristics called “Droop” are preset at the factory. If required, these shift characteristics can be reset by referring to Resetting Droop in this section.

Move the throttle lever to the FULL throttle position.

NOTE: Leave the throttle in the FULL throttle position when operating in AFO.

Use the gear selection switch and find the desired maximum gear for the field work being performed.

Press the bottom of the Autoshift switch to turn Auto Field Operation ON. Automatic shift range is now from the active gear when the switch is turned ON to any lower gear available.

NOTE: If current gear selected is higher than 14th when Auto Field Operation is turned ON, automatic shift range will default to 14th gear as the maximum gear to any lower gear available.

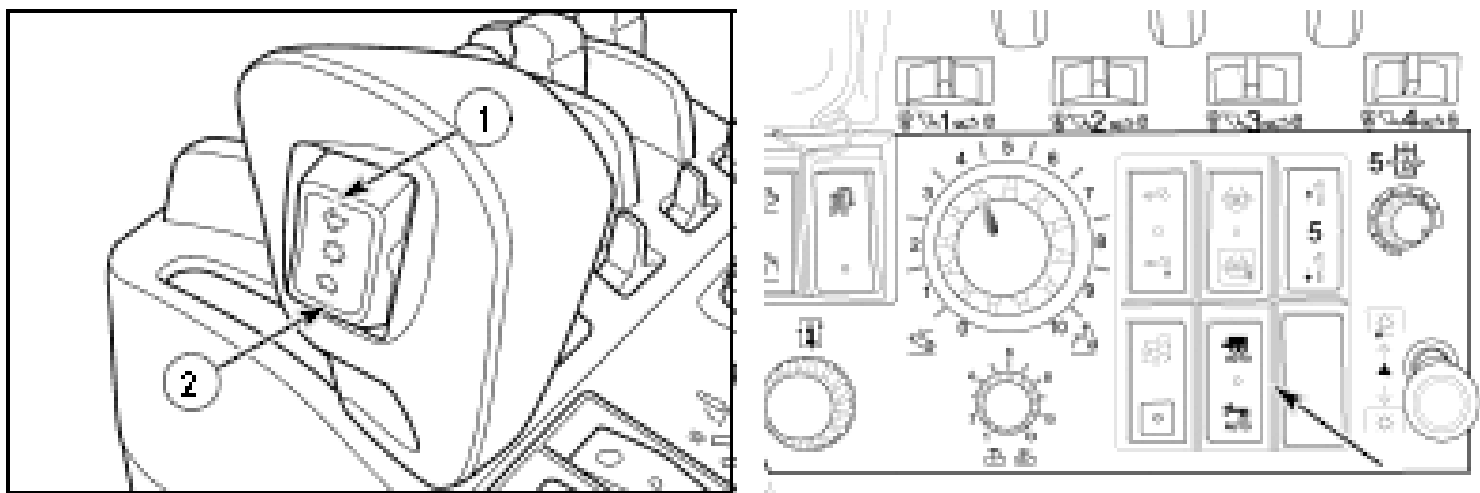

As load increases due to changing field conditions, the tractor downshifts the transmission automatically to maintain engine RPM. As load decreases, the tractor upshifts as required within the range, but to no gear higher than the active gear when Auto Field Operation was turned ON (14th gear if Auto Field Operation was turned on in 15th gear or above).

Magnum Series III Electronic End Of Row System Operation

The Electronic End of Row System will improve productivity and reduce operator fatigue by reducing the amount of functions cycled at the headlands. A simple push of a button will perform up to six different functions.

Controlled functions are:

- Shift the transmission up or down.
- Change the engine throttle position up or down.
- Set the remote hydraulics to any position.
- Position the hitch up or down.
- Control the MFD.
- Control the differential lock.

Recording a Sequence

1. Start the tractor and drive towards the headland with the implement. Press and hold the RECORD switch (1) in the armrest control panel until the second beep is heard. This will put the system in record standby mode. The Electronic End of Row screen will appear on the Performance Monitor.

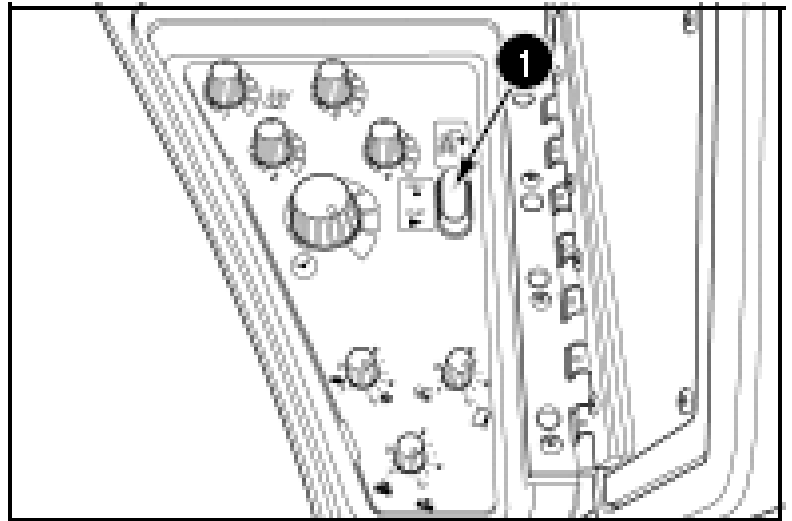

2. Press the top of the STEP switch (2) when the headland is reached. This will start recording. Cycle through the functions required to make the first half of the headland turn. For example for a hitch mounted implement, shift down, raise the hitch and decrease the throttle setting. Press the STEP switch (2) again to pause the recording. Make the turn with the implement and press the Step switch (2) again to resume recording.

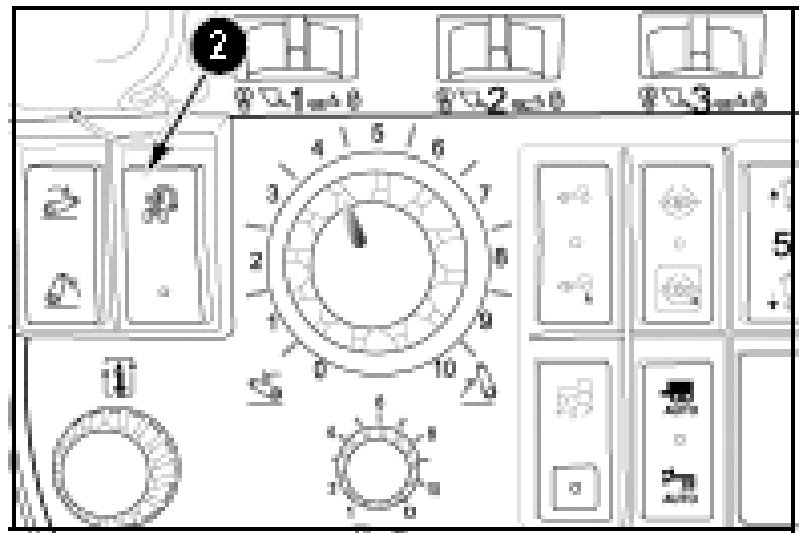















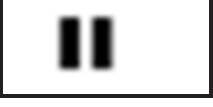
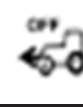

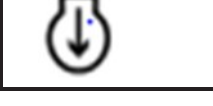

Cycle through the functions required to make the second half of the headland turn. For example, increase the throttle setting, lower the hitch and shift up.

3. Press the record switch to save the recording.

4. Selected function icons appear in the A post display. When the next function is selected, the prior selected function icon is moved under the square. Shown is the transmission up shift in the square with cylinder retract and engine rpm up below. See display icon chart for icon descriptions.

Display Icons

Icon Graphic	Description	Icon Graphic	Description
	Electronic End of Row System		Differential Lock Off
	Record		Differential Lock Auto
	Play		MFD On
	Pause		MFD Off
	Engine RPM up (throttle up)		MFD Auto
	Engine RPM down (throttle down)		Remote Cylinder Extend
	Hitch Raise		Remote Cylinder Retract
	Hitch Lower		Remote Cylinder Float
	Transmission Up-Shift		Remote Cylinder Neutral
	Transmission Down-Shift		Autoguidance Engage
	Differential Lock On		

**Mitchell
Equipment**
WE GOT YOUR BACK

CASE II
AGRICULTURE



**Mitchell
Equipment**

Jump Start Guide

2018 EDITION

402.925.5191

311 South Hwy 11 | Atkinson

www.MitchellEquip.com